

Important: Retain these instructions

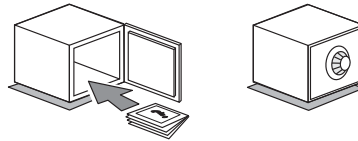

CONTENTS

1.1 Unpacking	1	2 Limitations of Use	14
1.2 Storing	1	3 Resetting the Node	16
1.3 Installation - Mounting	1	4 Disposal	16
1.4 Installation - Configuration	5		

1 Installation Instructions

1.1 Unpacking

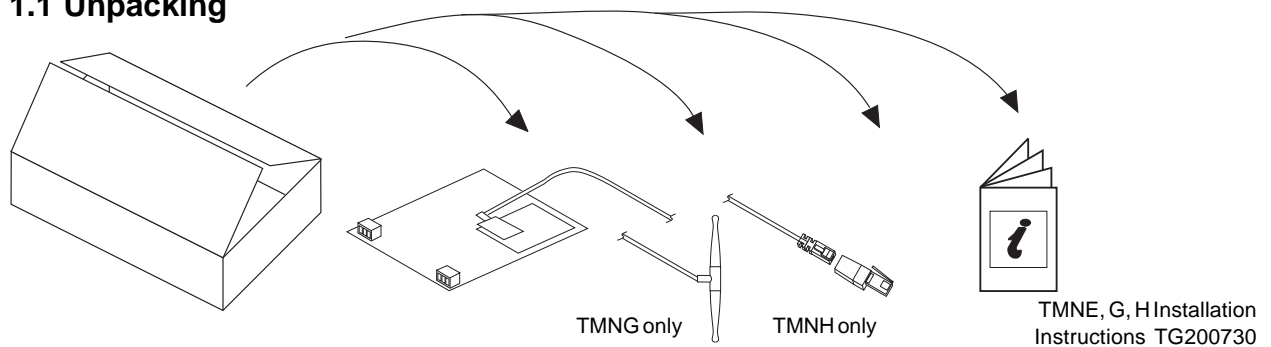

1.2 Storing

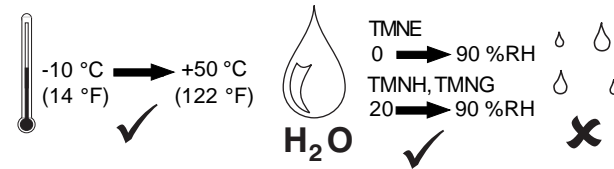

It is recommended that the installation should comply with the HSE Memorandum of Guidance on Electricity at Work Regulations 1989. For USA install equipment in accordance with National Electric Code

1.3 Installation - Mounting

Warning: Removal of the covers exposes dangerous voltages. 417-IEC-5036

Caution: The TMN contains static sensitive devices. Suitable anti-static precautions should be taken throughout this operation to prevent damage to the unit. BS EN100015/1 Basic Specification: protection of electrostatic sensitive devices.

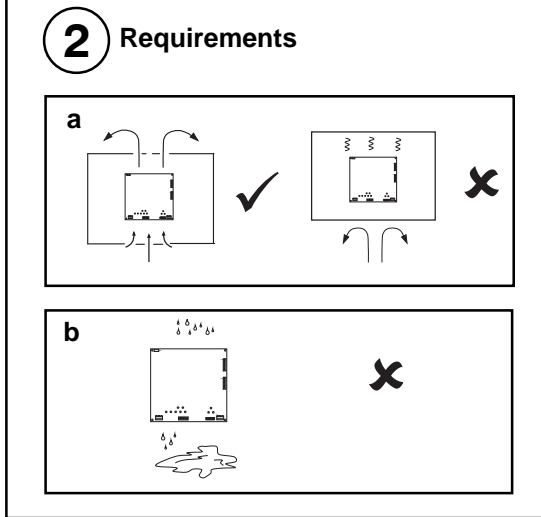
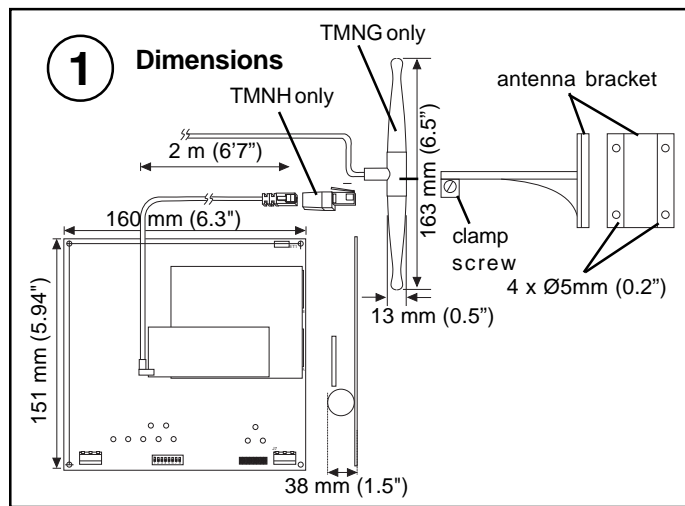

1.3 Installation - Mounting (continued)

2 Requirements (continued)

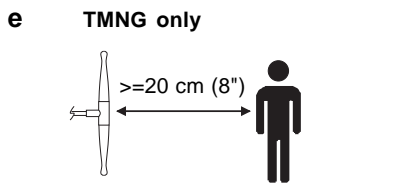
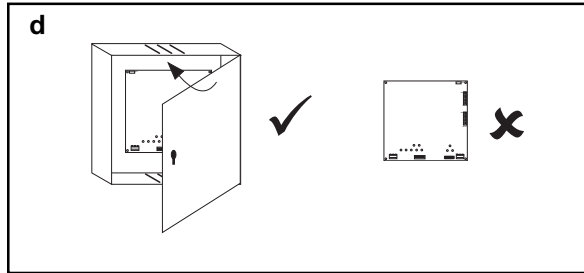
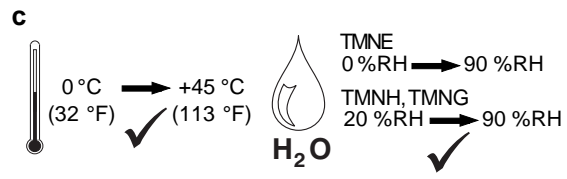

- f TMNG only**
- 1 Mount antenna away from sources of interference (e.g. domestic appliances, computer monitors or TV receivers, machinery with high HF leakage)
 - 2 Do not operate near unshielded or susceptible equipment (e.g. some vehicles, pacemakers, certain areas of hospital or medical centres, aircraft, areas designated blasting areas).

3 Mount the node

The TMN can be fitted into enclosures and controllers as shown in the table below:

UNIT	TMNE	TMNH <v4.4	TMNH v4.4	TMNG
NETB/NETBB	✓	✓	✗	✗
IQ10x+	✓	✓	✓ ^②	✓ ^②
IQ111+	✓	✓	✓ ^②	✗
IQ131+	✓	✓	✓ ^②	✗
IQ23x	✓	✓	✓	✗
IQ241/242	✓	✓	✓	✗
IQ25x	✓ ^①	✓ ^①	✓ ^①	✗

- Notes: ① TMN board fits with 3 screws in normal node position or fits in NDP position (if no NDP). Must use NDP position if RDS fitted.
 ② The board will not fit into the controller if a display panel is fitted.

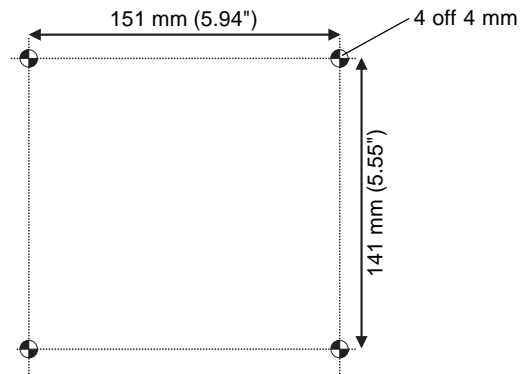

See appropriate enclosure/controller installation instructions for more details about node installation.

4 Mount Antenna TMNG only

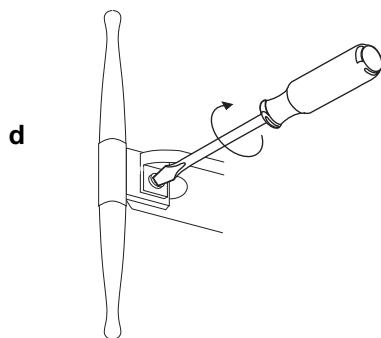
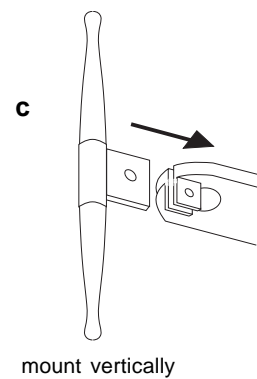
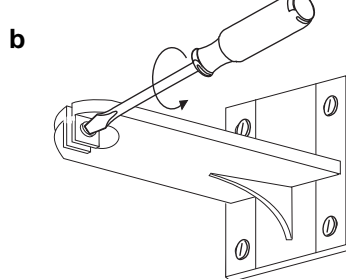
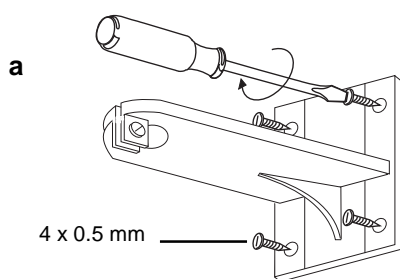

⚠ Only use the supplied antenna. An unauthorised antenna could damage the modem and may contravene local RF emission regulations or invalidate type approval

⚠ Do not use the modem with a damaged antenna. If a damaged antenna comes into contact with the skin a minor burn may result. Replace a damaged antenna immediately

1.3 Installation - Mounting (continued)

5 Connect input power supply TMN consumption <=7.5 VA

terminal size 0.5 to 2.5 mm² (20 to 14 AWG)

6 Connecting Ground

WARNING: This apparatus must be grounded

7 Connect Network
(unless direct connected to single device - old IQs or configuration)

Cable	1k2 baud	4k8 baud	9k6 baud	19k2 baud	38k4 baud	No. of Wires
Belden 9182	1000 m (1090 yds)	1000 m (1090 yds)	1000 m (1090 yds)	700 m (765 yds)	500 m (545 yds)	2
Belden 9207	1000 m (1090 yds)	1000 m (1090 yds)	1000 m (1090 yds)	500 m (545 yds)	350 m (380 yds)	2
Trend TP/1/1/22/HF/200 (Belden 8761)	1000 m (1090 yds)	1000 m (1090 yds)	700 m (765 yds)	350 m (380 yds)	250 m (270 yds)	2
Trend TP/2/2/22/HF/200 (Belden 8723)	1000 m (1090 yds)	1000 m (1090 yds)	500 m (545 yds)	250 m (270 yds)	125 m (135 yds)	4

terminal size 0.5 to 2.5 mm² (20 to 14 AWG)
polarity independent

additional terminals

Network Engineering Manual 92-1735

1.3 Installation - Mounting (continued)

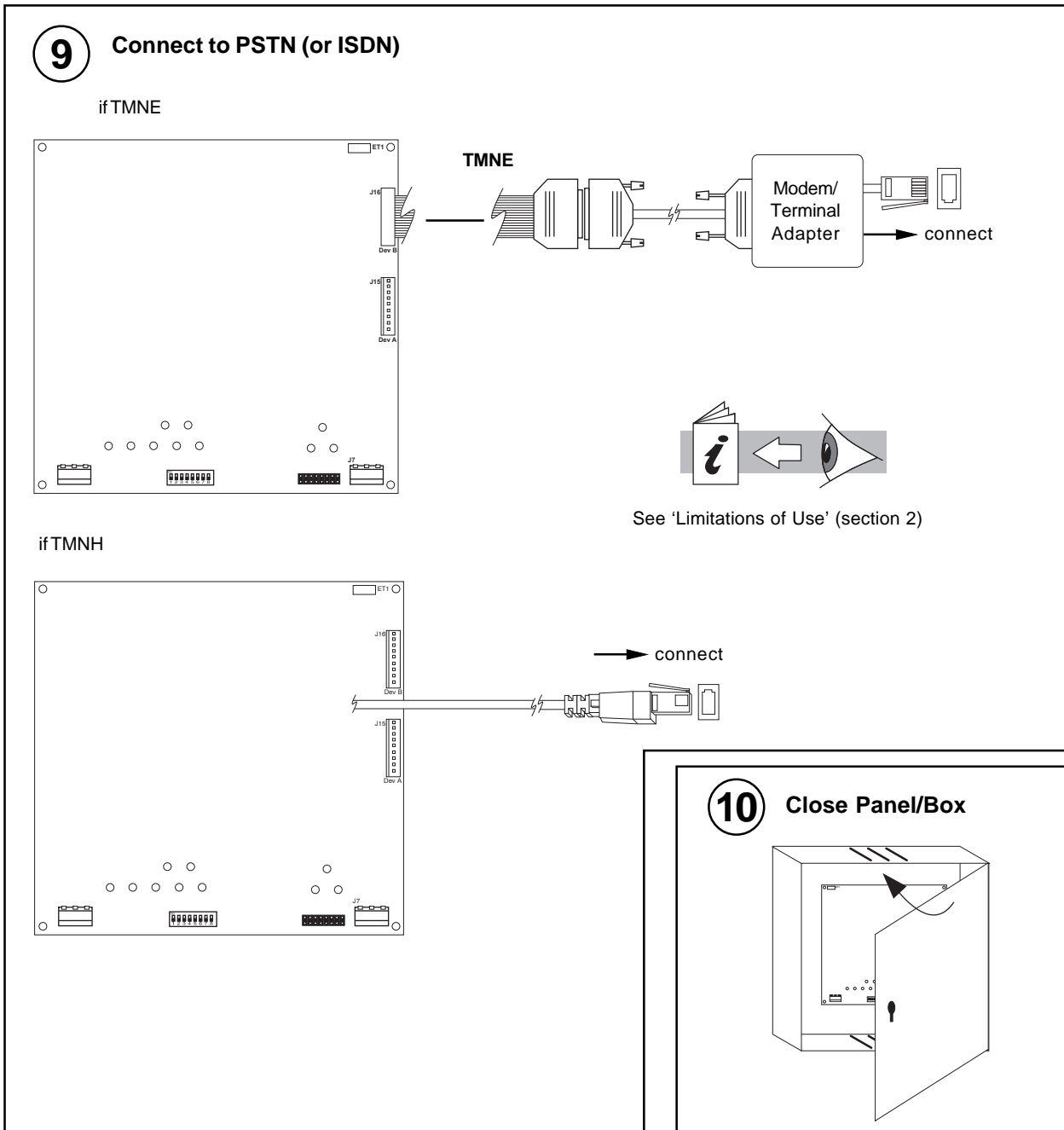
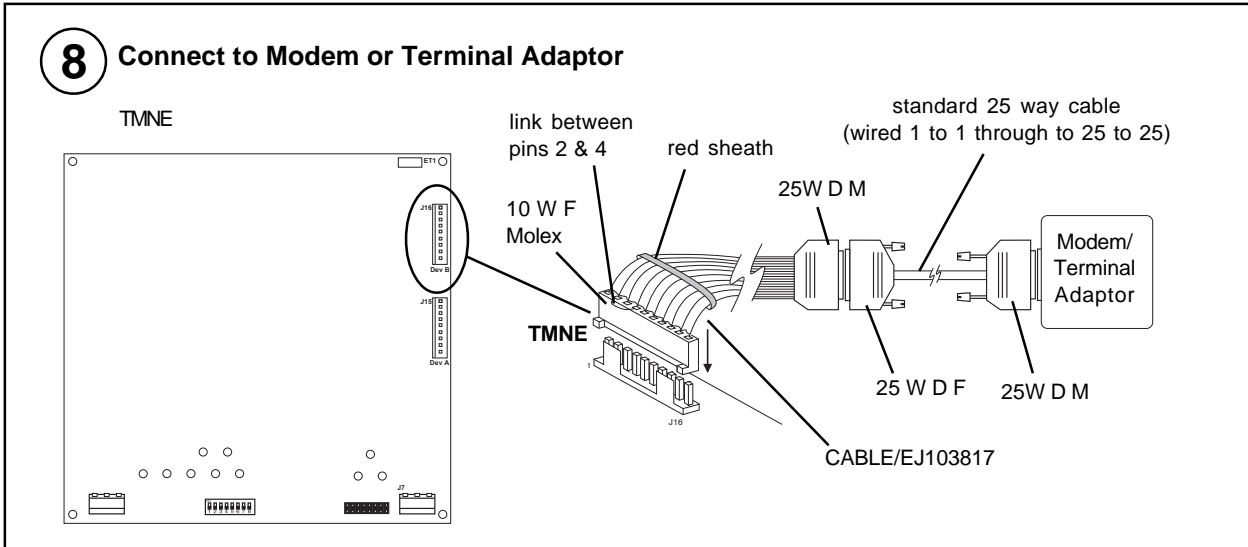

1.4 Installation - Configuration

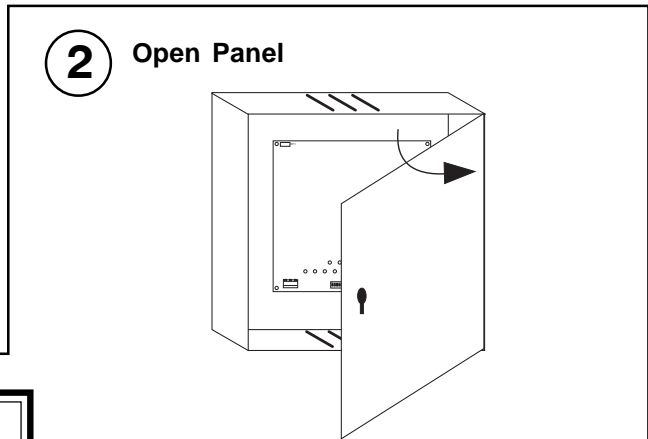
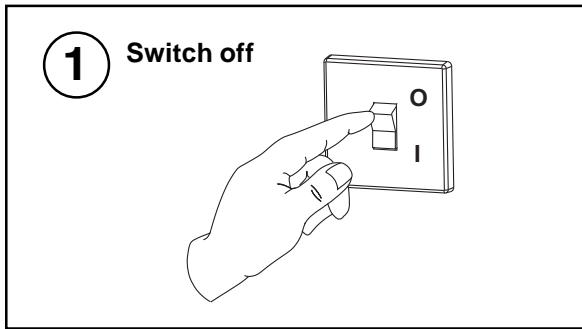

Caution: The TMN contains static sensitive devices. Suitable anti-static precautions should be taken throughout this operation to prevent damage to the unit.
 BS EN100015/1 Basic Specification: protection of electrostatic sensitive devices.

WARNING: Opening the panel may expose dangerous voltages.

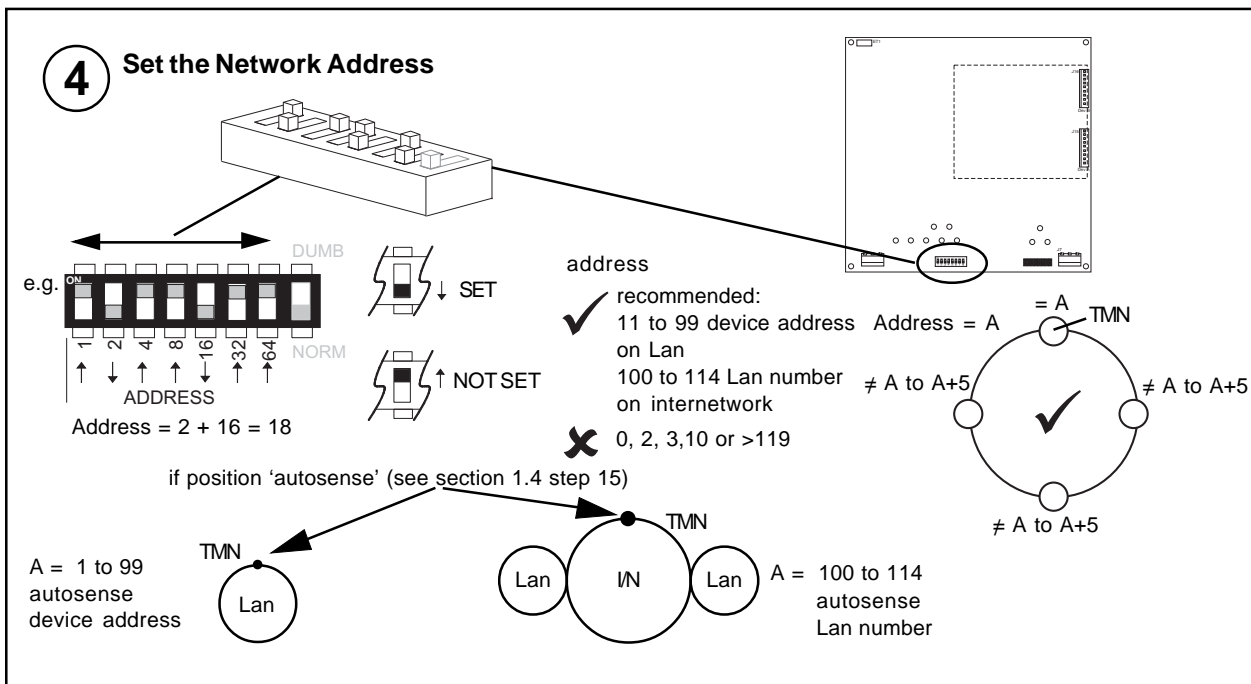
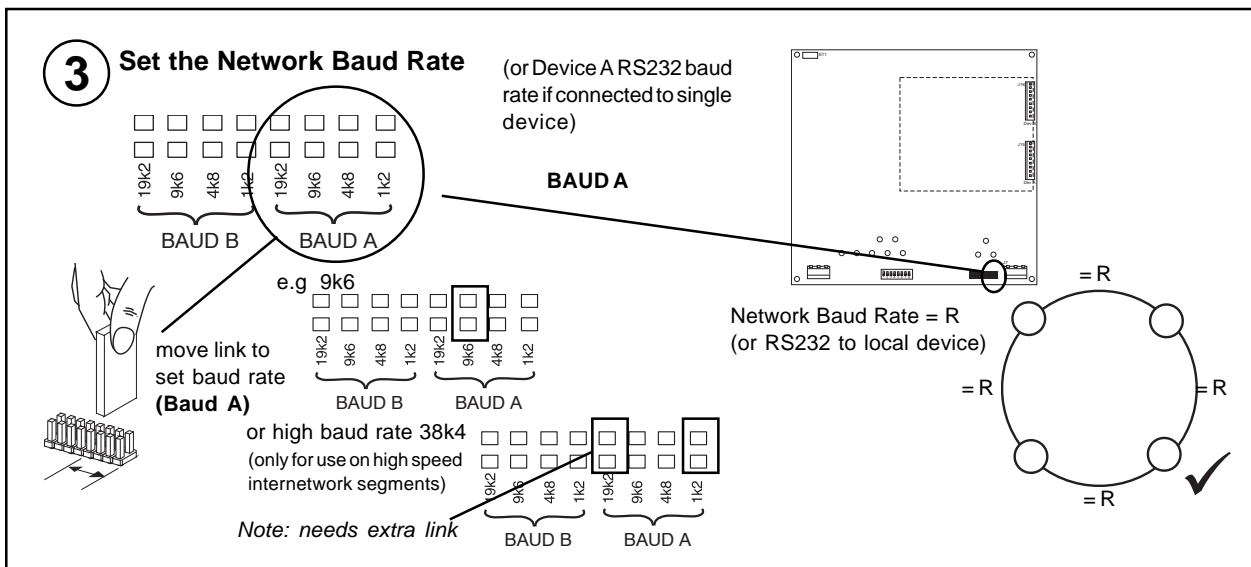

1.4 Installation - Configuration (continued)

5 Set Dumb/Normal switch

e.g. ON
1 2 4 8 16 32 64 NORM
ADDRESS

DUMB

Dumb only for pre Network+ (pre 1985)

Normal - For all other networks

6 Set modem/terminal adaptor baud rate

BAUD B

BAUD A
e.g. 19k2

move link to set baud rate (Baud B)

NOTE THAT BAUD RATE MUST BE 19k2 (default) FOR TMNH, TMNG

set baud rate to maximum baud rate of modem or terminal adaptor up to 19k2.

Modem or Terminal Adaptor Baud Rate = R2

= R2

TMNE

Modem or Terminal Adaptor

7 Connect to local device - if direct connected to single device

(for Old IQs or local configuration)

10 Way Female Molex links between pins 2-4, 3-5

black sheath

25 Way D type Female (old IQ)

Dev A

J15 (TMNE)
J4 (TMNH, TMNG)

Dev A

CABLE/EJ100179A001

J15, J4

Note: Connecting a cable to Dev A connector disables Lan A communications

1.4 Installation - Configuration (continued)

8 Plug in SIM Card (TMNG only)

a Obtain SIM Card

- 1 Contact a GSM service provider. (In UK Trend recommend O2 or Orange.)
- 2 Obtain a GSM data enabled SIM card with a data number (9600 bps) in addition to the normal voice number. (For O2 or Orange stress Mobile Terminator Data SIM required, if O2 also stress analog data number).
- 3 Communications with an /ADL require the SIM card to have a 2400 bps data number.
- 4 Request the GSM service provider to activate the SIM card end to turn off automatic SIM updates.
- 5 Clear the SIM's default password by plugging into a mobile phone and selecting security clearance from the menu. (Alternatively, to maintain password, set up 'Additional init string' in modem module, see 1.4 step 17.)

b Plug in SIM Card

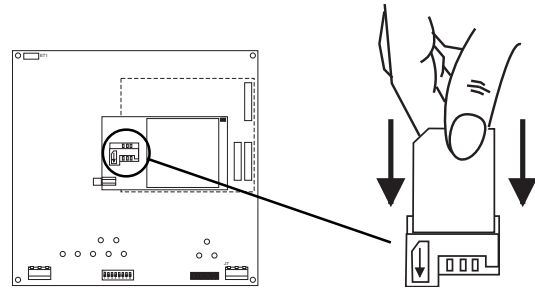

Note that plugging in the SIM card will result in some of the modem settings being cleared: they must be reconfigured as in 1.4 step 18.

9 Switch On

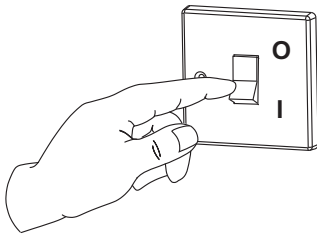

10 Check Node Controller

a PWR ON (green)



Check input power supply

b W/DOG (red)



TMN Faulty

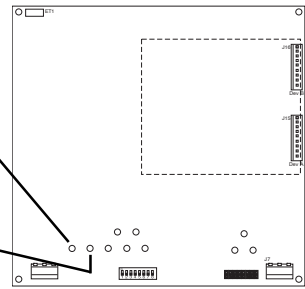

11 Check Network

Not if local device connector plugged into Dev A (1.4 step 7)

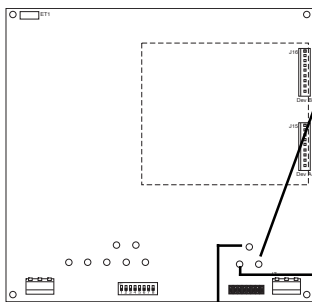

a RX A (yellow)



b TX A (yellow)



c OK A (green)

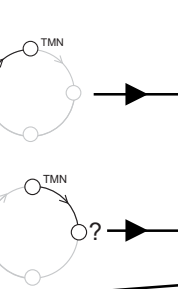

Network Address Invalid
0,2,3 or >119

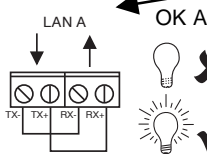

TMN Faulty

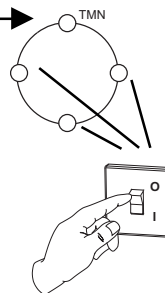
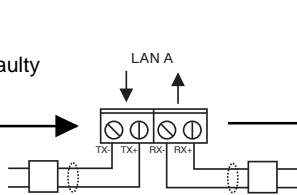

OK A
Check network cabling for short circuits with a multimeter (NOT Megger)

Check baud rate. Power up other nodes until faulty node is found (OK). Correct fault.

1.4 Installation - Configuration (continued)

12 Connect Local PC

J15 (TMNE)
J4 (TMNH, TMNG)

CABLE/58-0750

25 Way D type Male

9 Way D type Female

WupDn or PowerTool (not 962, 963 or 945)

13 Close Panel

14 Configure

Autodialling Manual, 90-1353
TMNE, G, H Data Sheet, TA200734

822Toolbox/921 only

TMN

- Use WupDn or PowerTool
- If on Lan or direct connected set Lan x, address = switch setting.
- If on Internetwork set Lan = switch setting and address = switch setting.

top Menu :
Status Record List Delaylist deFault Help eXit

e.g. F select deFault module

X to eXit module having changed parameter

Q to Quit module and discard changes

Note that a PIN may be required to make changes in configuration mode. If the PIN has been forgotten the user should contact Technical Support quoting the default generator number (Default module) whereupon a default PIN will be supplied. This will only work during the same configuration mode session i.e. the utility must not be exited between reading the generator and entering the default PIN. After the PIN is entered a new PIN should be set up and remembered.

1.4 Installation - Configuration (continued)

15 Check Settings - Default

Leave the following TMN default configuration settings unchanged for normal operation.

Default settings that can normally remain unchanged					
Parameter		Setting	Function	Condition	See Note
Record			All records clear		1
Default		access numBer	(blank)		
		Default answer mode	visitor network		
		Visitor network dial out	on		
		Position	autosense		2
	alarm reporting:	tExt	on		
	security:	Auto-dial password	off		3
		Config password	off		
dial-In		off			

Notes

- (1) If records are not being used, they should be kept clear so as not to duplicate addresses on local Lan.
- (2) The modification of **Position** to **localnet** or **internet** may prohibit further configuration (i.e. cannot be changed back) until general reset (see section 3). **DO NOT CHANGE UNLESS IMPERATIVE.**
- (3) If auto-dialling passwords are set incorrectly, **THEY WILL PROHIBIT COMMUNICATION.** There is a special procedure to correct password on remote TMN (see Auto-dialling Manual).

16 Settings to be Made

Set up following parameters for correct operation.

Settings that must be made						
Parameter		Setting	Function	Condition	See Note	
Default		own Tele	telephone number	telephone number of this TMN	all	
		oWn lan	Lan number	Lan number of this TMN	4, 5	
	alarm reporting:	addRes	network address	network address of TMN alarm target	all	6
		laN	Lan number	Lan number of TMN alarm target	if TMN on internetwork	4

Notes

- (4) **The oWn lan**, and **laN** parameters are alternatives which are not both available simultaneously: the **oWn lan** is only present when the TMN thinks it is positioned on the Lan, whereas the **laN** is only when positioned on the internetwork.
- (5) Always set TMN **oWn lan** number to match local INC address or (if no INC on Lan) to give identity to Lan.
- (6) The target TMN alarm address may be auto-dialled. If so it must be set up in a record of this TMN.

1.4 Installation - Configuration (continued)

17 Settings for special conditions

Set up following parameters if special conditions apply.

Settings to be made under special circumstances						
	Parameter	Setting	Function	Condition	See Note	
Record	addR	network address	network address of node being accessed	if being used by IQ controller, 822+/Toolbox, or for retransmission to a radiopager or mobile by a supervisor	7,8,9, 10,11	
	Lan	Lan number	Lan number of node being accessed	as above		
	Tele	telephone number	telephone number of node being accessed	as above	12, 18, 19	
	Ext. addr	extended address	additional protocol to select target device	if being used for radiopaging, set to radiopager 'pager number (space) password (space)'. For SMS set to mobile number.	19	
Default	access numBer	telephone number	additional 20 digit constant number substituted for letter B in telephone number	if telephone number exceeds 20 characters (e.g. for Mercury), can be used in TMN or supervisor records	12	
	Visitor network dial out	off	prohibits use of this TMN for dialling out by supervisor	if TMN is being reserved for incoming calls (e.g alarm priority) - only 921 v2.5, 94x, 96x series		
	Position	localnet	forces position to be on Lan independent of address setting	if addressing is becoming a problem	13	
		internet	forces position to be on internetwork independent of address setting			
	alarm reporting:	tExt	off	TMN's alarms reported in coded form	if sending to 921 v1 or 951 supervisors	14
	security:	Auto-dial password	matching password	if correct password is set up, it will enable access to protected TMNs	if sending to protected TMN, (password at each end must match)	15, 16
		Config password	a password	if set to a password will protect the TMN from configuration changes without entry of this password	if configuration changes need protecting	17
		dial-ln	on	Will only allow incoming messages if they come from an TMN with same auto-dial password	if this site needs protecting	15
Modem	Additional init string	null	Additional modem initialisation string to be sent to modem after fixed initialisation string	Do not change without instruction from technical support except for setting SIM PIN (TMNG only) or for SMS to multiple mobile phones	20, 21, 22	
	Sms text comms	off	Prohibits text comms by way of SMS (TMNG only)	if additional security required to stop a mobile user accessing parameters by using text comms		
	Max sms transmit per hour	(default =10)	Maximum number of SMS messages sent from TMG (TMNG only)	typical use is to send alarms to mobiles by SMS. This limits number and hence cost of calls		
	Restart tmn every 24 hours	on	TMN will restart every 24 hours after power up, (without AONL alarm generation).	if system experiences problems from interference		

Notes

- (7) If TMN being used by local 921 pre v 2.5, reserve record 2 for 921. (14) All alarms passed to radiopagers or by SMS must be text on alarms.
- (8) An outstation number may be entered in more than one record with different telephone numbers, so that if more than three failed attempts to connect have accumulated in the delay list, the TMN will proceed to use the next number on the next attempt (Alternative number dialling - see Auto-dialling Manual). (15) If using auto-dial passwords, make sure that all TMN/ANC+/ANDs involved have the same password set up, and have **dial-ln** set to **on**.
- (9) If a supervisor is passing alarms to a radiopager, the supervisor auto-dialling mechanism must not be used, instead the radiopager number must be set up in a TMN record. (16) If auto-dialling passwords are set incorrectly, **THEY WILL PROHIBIT COMMUNICATION**. There is a special procedure to correct password on remote TMN (see Auto-dialling Manual).
- (10) The target TMN alarm address may be auto-dialled. If so it must be set up in a record of this TMN. (17) There is a special procedure to clear a wrong, or forgotten configuration password (see Auto-dialling Manual).
- (11) The sharing of TMN/ANC+/AND and XN28s by a 940 or 943 may require the number to be set up in an TMN record rather than in the supervisor (see 1.4 step 20, 94x Series note). (18) If sending to radiopager, or sending to mobile by way of SMS bureau, set tele to bureau number prefixed by **RR**.
- (12) Telephone numbers may contain **A to Z, 0 to 9 # * ; < =** , the PABX number may be included (e.g. **9** to dial out, extension number to dial in) and special control characters:
J - wait for secondary dial tone, **K** -2 second pause
L - pulse dialling, **M** - tone dialling
B - substitute access number (not in access number itself) (19) If sending SMS directly to mobile (TMNG only) set Tele to mobile number prefixed by **SM**, and set Ext.addr to mobile number.
- (13) The modification of **Position** to **localnet** or **internet** may prohibit further configuration (i.e. cannot be changed back) until general reset (see section 3). **DO NOT CHANGE UNLESS IMPERATIVE**. (20) If setting up PIN to access SIM (TMNG only), set 'Additional Init String' to AT+CPIN=4321 (where 4321 is PIN)
(21) If sending SMS alarms to multiple mobile phones set 'Additional Init String' to AT+CPMS="BM". However, this will disable ability of mobile phones to communicate with TMN by text comms (see 1.4 step 20 - mobile phone). If sending many SMS alarms to multiple mobile phones use 963/SMS.
(22) If two or more AT commands are required in Additional Init String, concatenate them using ';'. e.g. AT+CPIN=4321;AT+CPMS="BM".

1.4 Installation - Configuration (continued)

18 Configure GSM modem settings
TMNG only

- As a result of inserting a SIM card (1.4 step 8), type 'init' from top level config prompts (see 1.4 step 14) to automatically re-initialize modem (V4.5 or greater only). For TMNG V4.4 only, the following settings must be entered manually:
- In configuration mode with the top menu prompts displayed, type 'direct'.
 - Type "dAT+CNMI=2,1,1,0,0" to enable SMS received notification
 - Type "dAT+CSMS=1" to set SMS commands to Phase 2+ version
 - Type "dAT+ILRR=0" to disable data rate reports
 - Type "dAT+CAOC=1" to disable charging information reports
 - Type "dAT+CMGF=1" to set SMS message mode to text
 - Type "dAT+CSMP=17,196,0,0" to set SMS validity period to 4 weeks
 - Type "dAT+CSAS" to save the SMS settings
 - Type "dAT&W" to save settings to modem stored profile

19 Exit Configuration

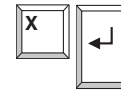
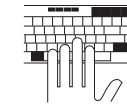

→ "Exit from Utility"

20 Set up device (communicating by way of TMN)

Devices:

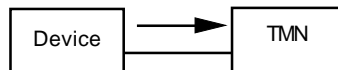

IQ
822+/Toolbox
WupDn

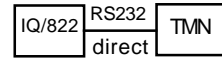
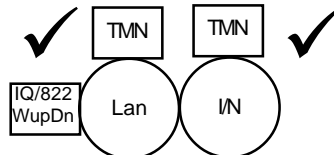

only old IQ or 822+/Toolbox - see 1.4 step 12

- For autodialed or critical alarms target, set Outstation address as appropriate with Lan number set to zero if TMN a local Lan, and set to destination Lan number if TMN on Internetwork. Put outstation address, Lan, and phone number in TMN record.
- IC Comms - use with caution - see Auto-dialling manual
- WupDn doesn't inform if connected
- If dialling a TMNG, use its data number

921 < v 2.5

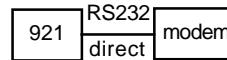
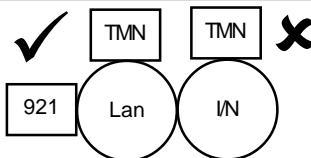

using SANC - no need for TMN.

- Use 921 auto-dialling mode. Use '==' method to put Lan number in auto-dial number table, and enter TMN address - see 921 Manual.
- If dialling a TMNG, use its data number

921 => v 2.5
SET

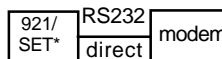
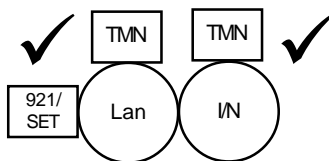

using SANC - no need for TMN.

*SET v4

- Use 921 auto-dialling mode. Either set autodialler address to 2 to find any available TMN (Lan or I/N), or set autodialler address to specific TMN address.
- If 921 shares TMNs/ANCs and XN28s then they must be specifically addressed.
- If dialling a TMNG, use its data number.

94x Series/962/963
(+841, 842, 843, 845)
PowerTool

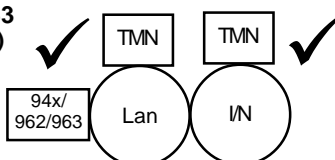

(---963 SMS ---)



mobile phone allows 963 to transmit text messages (SMS) to mobile phone, (no need for TMN)

- If 94x is using both TMNs/ANCs and XN28s then see Auto-dialling manual. If 94x is 945 1.01 or greater see 945 Engineering Manual.
- 962/963 can automatically seek next available autodialler (ANC, MNC, TMN, XN28) or can have particular devices allocated to particular autodiallers (e.g. to ensure XN28s are used correctly).
- If dialling a TMNG, use its data number
- In 963, using TMNG, in Tcommsrv.ini set IdleTimeToDropline=100, and RemoteATDSites=60000 and ensure [Grouping] has 'TMN-G=G'.
- In PowerTool using TMNG in TrendCommsCodes.ini change mG=German Modem to 'mG=TMN', and add 'cG=GSMIntegral'.

1.4 Installation - Configuration (continued)

20 Set up device (communicating by way of TMN) (continued)

915MDS, 916MDS ✓

915, 916 Lan IN TMN TMN ✓

915, 916 direct modem ✓ using SANC - no need for TMN

- Put outstation address, Lan, and phone number in TMN record.
- If dialling a TMNG, use its data number
- Can only dial into TMN, TMN cannot dial into 915 + modem. Dialling into TMN v4.1 needs manual addressing in 915, TMN >= v4.2 allows 915 to map site, and select device from map.

Mobile Phone

- A mobile phone can send text comms messages to TMNG only (see IQ configuration manual, 90-1533, for text comms codes)
- It must set telephone number to TMNG's data number
- Message must include outstation address, Lan no., and passwords e.g. **L1 O16 P1234 A1234 S1(\$,V)** -Note space between parameters
Lan 1, Outstation 16, outstation PIN 1234, Autodialling password 1234, Sensor 1 label(\$) and Value

21 Configure modem/terminal adaptor
TMNE only
 (TMN will initialize modem to settings stored in modem's memory)

a Connect to a PC

'PC' personal computer modem/terminal adaptor
 e.g. Windows terminal

b Recall Factory Settings

AT&F

c Make Settings: see Auto-dialling Manual AND section for example settings.

- Dropping DTR causes modem or terminal adaptor to terminate call and enter command mode (AT&Dn).
- DCD is used to indicate a call connected (AT&Cn).
- Modem or terminal adaptor baud rate must be locked to TMN speed (locking DTE speed) (AT&Bn).
- RTS/CTS flow control is enabled (XON/XOFF disabled) (AT&Hn).
- No echo of TMN commands by the modem (ATEn).
- Modem or terminal adaptor message indicating call progress must be numeric (ATVn).
- Turn off data compression (AT&Kn).

If unclear, check with Technical Support.

d Store Settings as default: AT&W0
 AT&W1

22 Check Signal Strength
TMNG only

either **use TMNG**

- Enter configuration mode (see 1.4 steps 12, 13, 14, above).
- Type 'direct' at top configuration menu prompts.
- Type 'dAT+CSQ' to request signal strength.
- Value is of form x,y. If x < 18 or = 99 relocate antenna and try again (see section 1.3, steps 2f, 4).
- Exit Configuration mode (see 1.4 step 19) and reconnect system.

or **use a mobile phone**

- Use a mobile phone using the same service provider (see 1.4 step 8).
- Check its indicator shows a good signal strength at location of TMNG antenna. If not relocate antenna and try again (see section 1.3, steps 2f, 4).

23 Check Modem Mode LED
TMNG only

- 1 Open panel (see 1.4 step 2)
- 2 Check Modem mode LED

modem mode (red)

- check power to modem
- check SIM activated, check SIM password
- slow on network
- fast active call

- 3 Close panel (see 1.4 step 13)

1.4 Installation - Configuration (continued)

24 Install auto-dialled end

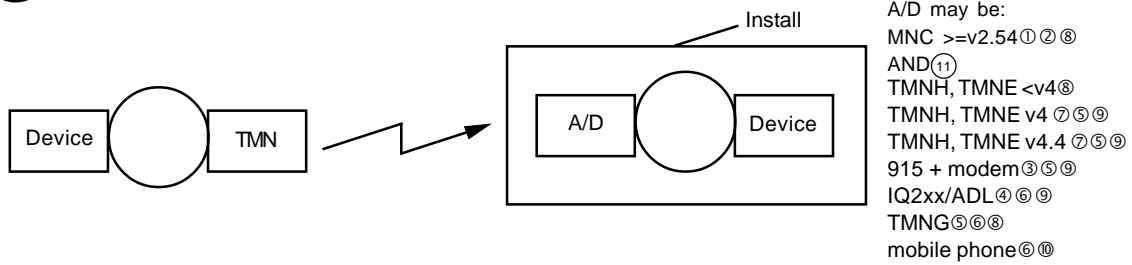

- ① When MNC dials into TMN it must have telephone number prefixed with SW.
 - ② TMNE may not be able to communicate with MNC if its modem cannot achieve V21.
 - ③ TMN cannot dial into 915 + modem but 915 + modem can dial into TMN >= v4.
 - ④ TMN must be >= v4.
 - ⑤ To dial a TMNG, must use the TMNG's data number
 - ⑥ To communicate with an IQ2xx/ADL a TMNG must have a 2k4 bps enabled SIM and the IQ2xx/ADL must dial the TMNG's 2k4 bps data number
 - ⑦ To communicate with TMNG, adjust TMN v4.3 or greater Modem Link configuration setting 'Originate Msg Delay' to 10 secs.
 - ⑧ MNC or TMNH, TMNE <v4.3 cannot communicate with TMNG
 - ⑨ TMNH, TMNE must use BT landline to dial TMNG
 - ⑩ Mobile phone can be dialled from TMNE, TMNH by SMS bureau or direct by TMNG. Mobile phone can only dial TMNG.
 - ⑪ TMNG can dial into AND v2.5, but AND v2.5 cannot dial into TMNG.
- Enter configuration mode (see 1.4 steps 12, 13, 14 above).
 - Type 'modem' at top configuration menu prompts.
 - Type G3X to set 'oriGinate msg delay time' to 10s.
 - Type X to exit configuration mode (see step 22).

25 Test System

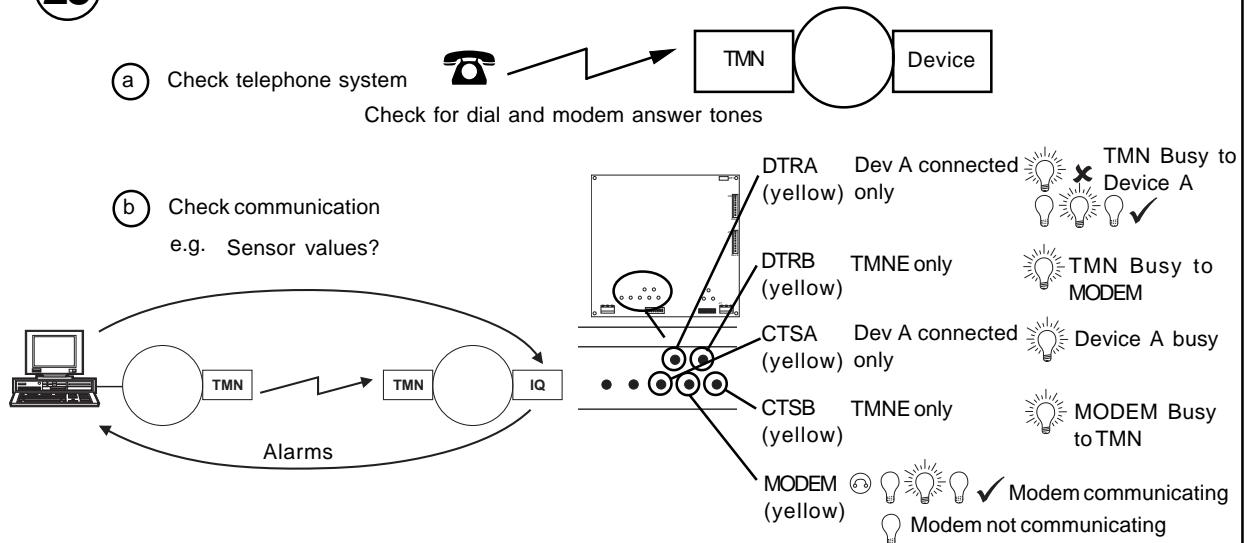

Dialling messages are displayed by some supervisors and may help fault diagnosis.

DIALLING 01234123456	Dialling the number
UNOBTAINABLE WAIT xmxs	Modem has dialled and obtained busy signal or number unobtainable (must wait for delay to expire)
CONNECTED 01234123456	Connection achieved between IQ systems
DISCONNECTED 01234123456	Modem disconnected due to time out, or manual override
LINK-FAIL 01234123456	Failure of current link
REMOTE DISCONNECTION	Another device has requested priority use of far end modem
LOCAL DISCONNECTION	Another device has requested priority use of local modem
SECURITY FAIL	Auto-dial passwords do not match between TMNs.

In addition to normal network alarms the following alarms may be sent from the TMN to the TMN alarm destination node:

AONL (Autodialler on line)	TMN powered up
BTNR (No answer far site)	Lines engaged or telephone fault caused five failed attempts to connect. Further dialling inhibited until re-dial delay expired (or general reset).
LINR (No dial tone)	Modem fails to produce dial tone at start of call.
MONR (Local modem fault)	Modem failed to acknowledge request to dial.
PGNR (Pager bureau fault)	Pager failed to receive message although connection to pager bureau achieved.

1.4 Installation - Configuration (continued)

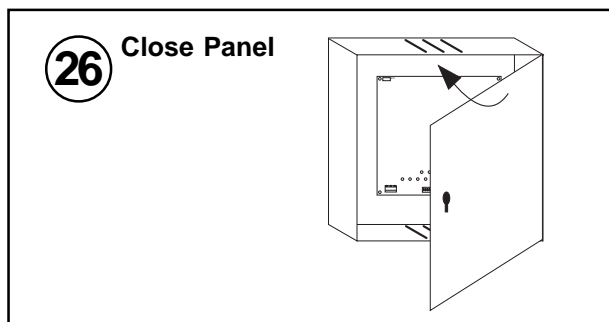

2 Limitations of Use

2.1 TMNH INTEGRAL MODEM (MT5600SMI-92)

2.1.1 Approvals

The CE and UL Approvals are defined in the Specification (Environmental) section of the TMNE, G, H data sheet (TA200734).

2.1.2 General

Host Equipment: The TMNH consists of the TMN host with the attached modem daughter board. The TMN host fully complies with the requirements necessary for the EC24 modem regulatory requirements if it is operated within the specification defined in the TMNE, G, H data sheet (TA200734). The modem is supplied to be used solely within the TMNH.

Safety: The modem comprises two sections of circuitry, namely a telecommunications interface and a host interface, which are separated by a safety barrier that meets the reinforced level of isolation at 250Vrms. The modem cannot be used in host equipment that use or generate voltages in excess of 250 Vrms.

The telecommunications interface is approved to be connected to telecommunication network voltage circuits which may carry dangerous voltages.

The telephone cord must remain disconnected from the telecommunications systems until the **MT5600SMI-92** modem has been installed within a host which provides the necessary protection for the operator. If it is subsequently desired to open the host equipment for any reason, the telephone cord must be disconnected prior to effecting access to any internal parts which may carry telecommunication network voltages.

The integrity of the telephone line cord, connected to the modem, should not be compromised by wear or proximity to hazardous voltages, as defined by EN60950.

The modem RJ11 PSTN network connector port type is TNV-3.

The local environment within the host must not be subject to conductive pollution or to dry non-conductive pollution which could become conductive due to condensation.

Power is supplied to the modem through the host interface connector.

Network: External control software for this unit must comply with the following requirements. No other modes of operation should be used on the PSTN and the use of such modes invalidates the approval.

1. It must not allow the "S" register values to be set outside the following ranges: S6 (delay for blind dialling): 4 only, ie default value.

2. When dialling out, the number of "," pauses inserted between digits in a dialled number must not exceed 5.

The modem is suitable for connection to PSTN direct exchange lines and/or to an approved private branch exchange. It may be connected to any PSTN direct exchange line except as an extension to a pay-phone, or shared service.

The modem has a REN (ringer equivalence number) of 0.1B. The REN is a customer guide indicating the maximum number of items of apparatus that should be connected simultaneously to the line. The total REN value must not exceed the maximum REN value of 4.

2.1.3 Country Specific Information

USA

FCC Part 15 Regulation

This equipment has been tested and found to comply with the limits for a **Class B** digital device, pursuant to Part 15 of the FCC rules. These limits are designed to provide reasonable protection against harmful interference in a residential installation. This equipment generates, uses, and can radiate radio frequency energy, and if not installed and used in accordance with the instructions, may cause harmful interference to radio communications. However, there is no guarantee that interference will not occur in a particular installation. If this equipment does cause harmful interference to radio or television reception, which can be determined by turning the equipment off and on, the user is encouraged to try to correct the interference by one or more of the following measures:

Reorient or relocate the receiving antenna.

Increase the separation between the equipment and receiver.

Plug the equipment into an outlet on a circuit different from that to which the receiver is connected.

Consult the dealer or an experienced radio/TV technician for help.

This device complies with Part 15 of the FCC rules. Operation of this device is subject to the following conditions: (1) This device may not cause harmful interference, and (2) this device must accept any interference that may cause undesired operation.

WARNING – Changes or modifications to this unit not expressly approved by the party responsible for compliance could void the user's authority to operate the equipment.

47 CFR Part 68 Telecom

1. This equipment complies with Part 68 of the 47 CFR rules and the requirements adopted by the ACTA. Located on this equipment is a label that contains, among other information, the registration number and ringer equivalence number (REN) for this equipment or a product identifier in the format: The registration number is AU7/USA-46014-MD-E

The REN is 0.1B

REN: For Canada the sum of the RENs of all the devices must not exceed five".

The jack plug used to connect the TMNH to the premises wiring and telephone network is RJ11, which complies with the applicable 47 CFR part 68 rules and requirement adopted by the ACTA

Canada

Regulatory Requirements for Canada

The following requirements are established under section 69.3 of the *Telecommunications Act* for purposes of section 5 of the *Telecommunications Apparatus Regulations*.

The equipment bears the following identifying marks, which are permanently affixed to the equipment:

(a) The registration number — Specifications of this mark are given in the document: IC: 125 1142A

(b) The model identification number under which the product was registered: MT5600SMI

2 Limitations of Use (continued)

“This product meets the applicable Industry Canada technical specifications”

The REN is 0.1B

REN: For Canada **the sum of the RENs of all the devices must not exceed five”.**

Industry Canada

This Class B digital apparatus meets all requirements of the Canadian Interference-Causing Equipment Regulations.
Cet appareil numérique de la classe B respecte toutes les exigences du Règlement Canadien sur le matériel brouilleur.

New Zealand

New Zealand Telecom Warning Notice

1. The grant of a Telepermit for any item of terminal equipment indicates only that Telecom has accepted that the item complies with minimum conditions for connection to its network. It indicates no endorsement of the product by Telecom, nor does it provide any sort of warranty. Above all, it provides no assurance that any item will work correctly in all respects with another item of Telepermitted equipment of a different make or model, nor does it imply that any product is compatible with all of Telecom's network services. This equipment is not capable under all operating conditions of correct operating conditions of correct operation at the higher speed which it is designated. 33.6 kbps and 56 kbps connections are likely to be restricted to lower bit rates when connected to some PSTN implementations. Telecom will accept no responsibility should difficulties arise in such circumstances.

2. Immediately disconnect this equipment should it become physically damaged, and arrange for its disposal or repair.

3. This modem shall not be used in any manner which could constitute a nuisance to other Telecom customers.

4. This device is equipped with pulse dialing, while the Telecom standard is DTMF tone dialing. There is no guarantee that Telecom lines will always continue to support pulse dialing. Use of pulse dialing, when this equipment is connected to the same line as other equipment, may give rise to 'bell tinkle' or noise and may also cause a false answer condition. Should such problems occur, the user should NOT contact the Telecom Faults Service. The preferred method of dialing is to use DTMF tones, as this is faster than pulse (decadic) dialing and is readily available on almost all New Zealand telephone exchanges.

7. Some parameters required for compliance with Telecom's Telepermit requirements are dependent on the host associated with this device. The associated equipment shall be set to operate within the following limits for compliance with Telecom's Specifications:

For repeat calls to the same number: There shall be no more than 10 call attempts to the same number within any 30 minute period for any single manual call initiation, and the equipment shall go on-hook for a period of not less than 30 seconds between the end of one attempt and the beginning of the next attempt.

For automatic calls to different numbers:

The equipment shall be set to ensure that automatic calls to different numbers are spaced such that there is no less than 5 seconds between the end of one call attempt and the beginning of another.

8. For correct operation, total of the REN's of all devices connected to a single line at any time should not exceed 5.

South Africa

This modem must be used in conjunction with an approved surge protection device.

International use

The modem is approved in the UK, USA,- Australia, Austria, Belgium, Canada, China, Cyprus, Denmark, Eire, Finland, France, Germany, Greece, Holland, HongKong, Hungary, India, Italy, Japan, Luxembourg, New Zealand, Norway, Poland, Portugal, Russia, Singapore, Spain, Sweden, Switzerland, and many other countries. Check with Technical support for other countries.

If a country is not supported, the TMNE may be used with an external modem which is approved in that country.

International Modem Restrictions

Some dialing and answering defaults and restrictions may vary for international modems. Changing settings may cause a modem to become non-compliant with national telecom requirements in specific countries. Also note that some software packages may have features or lack restrictions that may cause the modem to become non-compliant.

EMC, Safety, and R&TTE Directive Compliance

The CE mark is affixed to this product to confirm compliance with the following European Community Directives: Council Directive 89/336/EEC of 3 May 1989 on the approximation of the laws of Member States relating to electromagnetic compatibility; and Council Directive 73/23/EEC of 19 February 1973 on the harmonization of the laws of Member States relating to electrical equipment designed for use within certain voltage limits; and Council Directive 1999/5/EC of 9 March on radio equipment and telecommunications terminal equipment and the mutual recognition of their conformity.

2.2 TMNG Integral GSM Modem (MTSMC-G-F1)

2.2.1 Safety Standards

THIS GSM MODEM COMPLIES WITH ALL APPLICABLE RF SAFETY STANDARDS.

This GSM modem meets the standards and recommendations for the protection of public exposure to RF electromagnetic energy established by governmental bodies and other qualified organizations, such as the following :

Directives of the European Community,
Directorate General V in Matters of Radio Frequency Electromagnetic Energy

2.2.2 GSM compliance

The SocketModem is in compliance with reference regulations: EN301 511 v7.0.1

2.2.3 CE Label

The Wireless SocketModem is CE compliant, which implies that the modem is in conformity with the European Community directives and it bears the CE label.

3 Resetting the Node

1 Open Panel

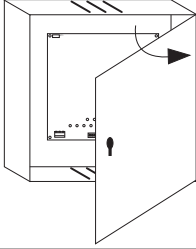

WARNING: Opening the panel may expose dangerous voltages.
417-IEC-5036



2 Check Network Address and Dumb/Normal Switch

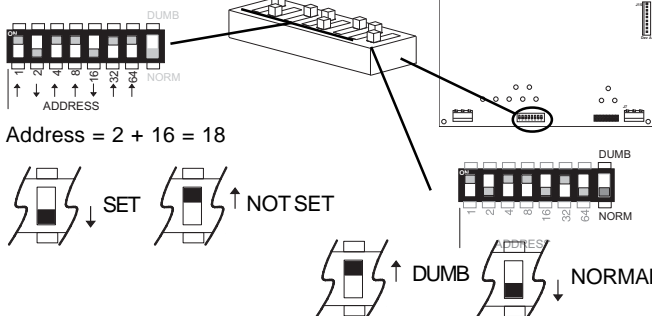

Address = 2 + 16 = 18

SET (switch down), NOT SET (switch up)

DUMB (switch up), NORMAL (switch down)

3 Set all Poles to Zero

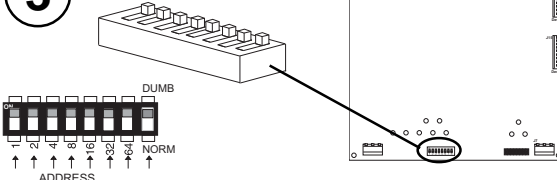

4 Wait 3 Seconds

OK A (green)

3 s

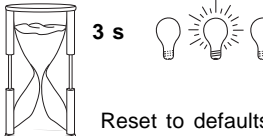

Reset to defaults (clears records, delay list, password, sets default module to defaults).

5 Set Network Address Dumb/Normal Switch

Section 1.4 steps 4, 5

6 Configure

Section 1.4 steps 12 to 19

7 Close Panel

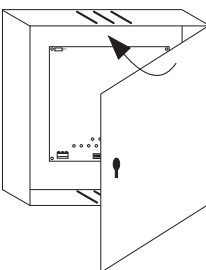

4 Disposal

WEEE Directive :



At the end of their useful life the packaging, product, and batteries should be disposed of by a suitable recycling centre.
Do not dispose of with normal household waste.
Do not burn.

Please send any comments about this or any other Trend technical publication to techpubs@trendcontrols.com

© 2009 Honeywell Technologies Sàrl, ECC Division. All rights reserved. Manufactured for and on behalf of the Environmental and Combustion Controls Division of Honeywell Technologies Sàrl, Z.A. La Pièce, 16, 1180 Rolle, Switzerland by its Authorized Representative, Trend Control Systems Limited.

Trend Control Systems Limited reserves the right to revise this publication from time to time and make changes to the content hereof without obligation to notify any person of such revisions or changes.

Trend Control Systems Limited

P.O. Box 34, Horsham, West Sussex, RH12 2YF, UK. Tel:+44 (0)1403 211888 Fax:+44 (0)1403 241608 www.trend-controls.com

Trend Control Systems USA

6670 185th Avenue NE, Redmond, Washington 98052, USA. Tel: (425)897-3900, Fax: (425)869-8445 www.trend-controls.com