

### IQ3.../.../XNC/...



### Description

The IQ3.../.../XNC/... provides a flexible way of interfacing the IQ system with 3rd party systems. It utilises both standard IQ configuration modules, and the Trend Custom Language (TCL) to present information from other systems as though it were from an IQ controller. It also allows parameters within the 3rd party system to be adjusted from IQ system Supervisor and Tool software. The optional serial auxiliary board (/SER/) provides an additional RS232 or RS485 (2/4 wire) (or also RS422) port for communicating with other devices.

*Note that standard IQ3 functionality is described in the IQ3 data sheet TA200505; this IQ3.../.../XNC/... data sheet describes the additional functionality of the XNC/.. and XNC/SER/.. options.*

### Features

- Flexible method of interfacing with 3rd party systems.
- Enhanced Custom Language (TCL).
- Standard IQ configuration modules.
- Serial auxiliary board option (RS232 or RS485(2/4 wire))

### Physical

Diagram shows IQ3XCITE/96; other versions have less I/O connectors

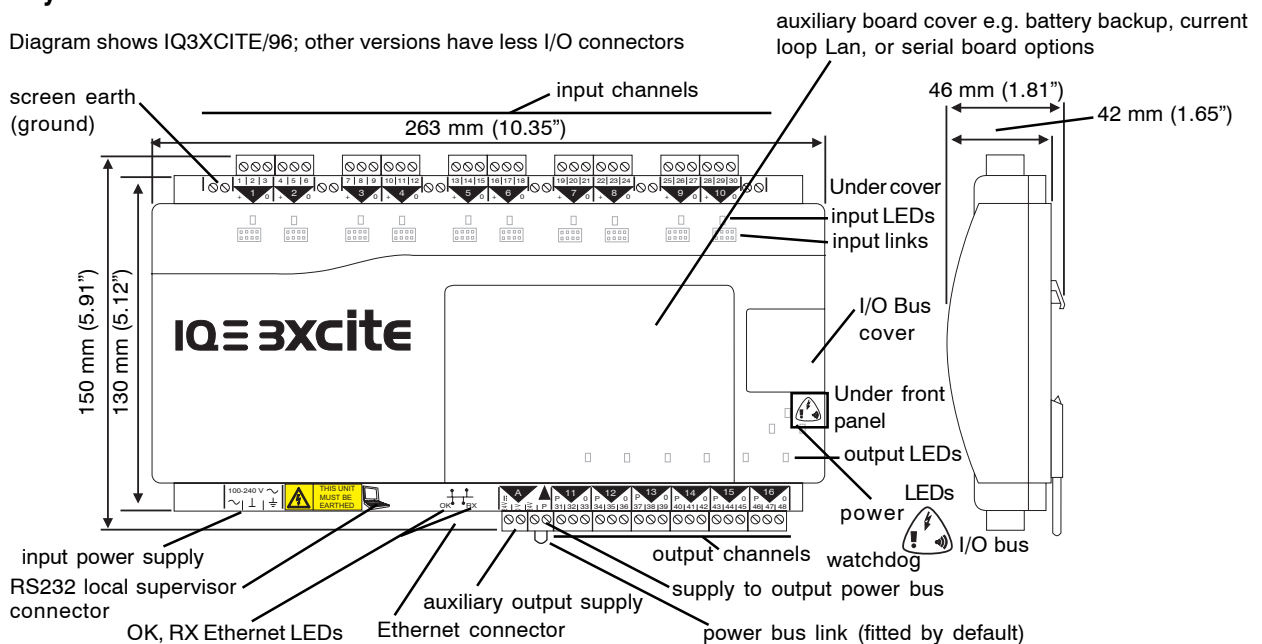

**Physical** (continued)

/IQ3../.../XNC/LAN/... only

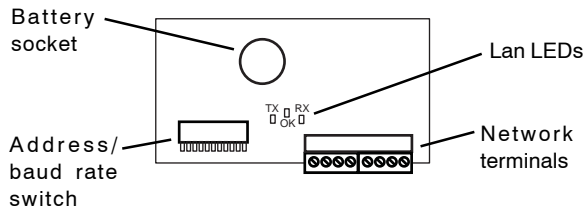

IQ3../.../XNC/SER/... only

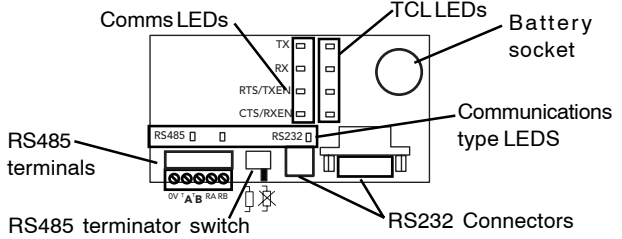

**FUNCTIONALITY**

The IQ3../.../XNC/... (henceforth known as IQ3/XNC) enables interfacing between the IQ system and 3rd party systems. The functionality can be divided into three sections: system, firmware, and hardware. Special additional firmware can be provided by a TCL application; these are created by Trend Interface Specialists (TIS) who can provide both bespoke applications and generic applications for commonly used equipment. The TIS may provide the application in soft format, or pre-loaded into the IQ3. The application can be tied to one controller or available for general download. Information about the TISs can be found on the Trend Partnernet website.

**SYSTEM**

**Standard Communications**

The full IQ3 has Ethernet, I/O bus and RS232 ports:

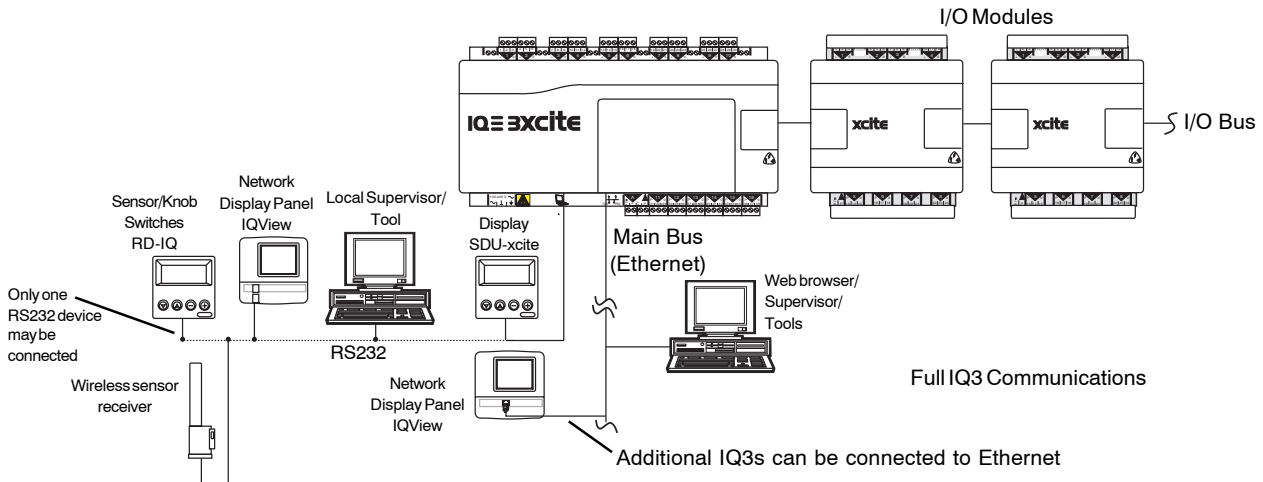

The above diagram shows the usage of the three communications interfaces used in the standard IQ3:

**Ethernet:** This enables  
 IP communications with the IQ3 (e.g. from a web browser)  
 Network creation on Ethernet (Lans and internetwork)  
 Trend communications from a supervisor or tool by use of IQ3 vCNC  
 IC communications between controllers  
 Email alarms from IQ3  
 IP alarms from IQ3  
 Download from SET of strategy and all other configuration files

**RS232:** This enables  
 Local supervisor, tool, display, or wireless sensor receiver to communicate with local IQ3 and, in some cases, over the network.

**I/O Bus:** This enables  
 The expansion of I/O capability by connection of I/O bus. Up to 80 extra I/O channels can be added to the IQ3xcite/96.

**Optional Communications**

**IQ system Current Loop Lan Auxiliary Board (/LAN/... option)**  
 This enables the IQ3 to become a device on an IQ system current loop Lan and to be able to perform normal Lan communications (e.g. IC Communications, Communications with a Supervisor, Tool, or Display)

It can no longer be part of an Ethernet Lan or internetwork, and can no longer communicate over Ethernet using IC Communications. However, all the other types of Ethernet communications listed above still operate.

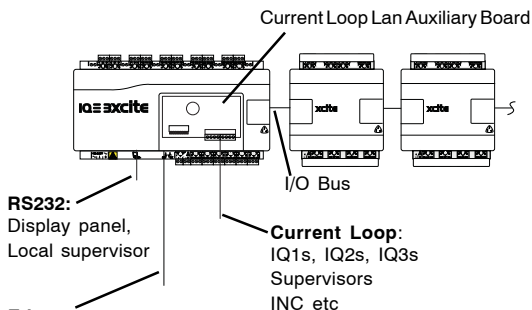

The IQ system current loop Lan connection enables the IQ3 to become part of an IQ system current loop Lan including IQ1s, IQ2s, other IQ3s, supervisors, and node controllers. It also enables the strategy file (but not other configuration files: language, backdrop, XNC (for IQ3/XNC only)) to be downloaded from SET across the current loop.

**Serial Auxiliary Board (/SER/... option)**

This auxiliary board is only available as an option on an IQ3/XNC controller and enables it to communicate with a 3rd party system using the extra serial interface. It expands the standard communications interfaces by adding an extra serial interface which may be either RS232, RS485 2 wire, or RS485 4 wire (which can also be used for RS422 applications); the required interface is selected within the TCL application.

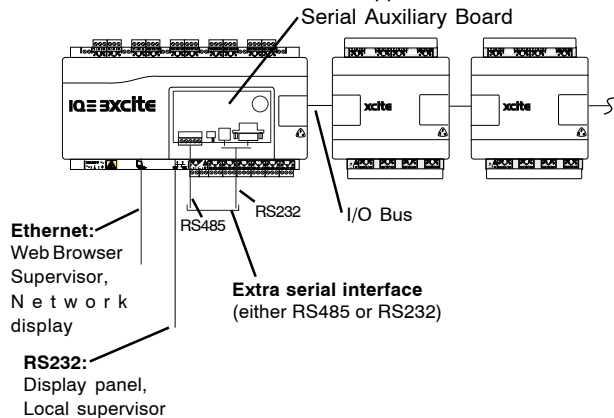

**BACnet Protocol Option (/BAC option)**

IQ3/BAC versions of IQ3 support BACnet over IP protocol as described in the IQ3 Data sheet.

**FIRMWARE**

The firmware within the IQ3/XNC consists of two parts: the device part, and the XNC part. The device part (standard IQ3 firmware) consists of a number of standard IQ configuration modules, and operates in exactly the same way as a standard IQ3 controller. These modules can be linked together to form a strategy in the normal way and the strategy may be used to manipulate the data from the 3rd party system. The XNC part runs a Trend Custom Language program (TCL application). It communicates with the 3rd party system, passing information from the IQ3 to the 3rd party system, and writing values from the 3rd party system to the IQ3. It can also communicate directly with IQ system devices. Communications with both 3rd party system and IQ system devices may be by means of Ethernet, current loop network (if /LAN/.. option fitted), or RS232/RS485 (if /SER/.. option fitted).

*Note that the XNC part may also be used to enhance the strategy without recourse to a 3rd party system.*

**Note that the IQ3/XNC functionality consists of the device part (normal strategy) plus the XNC part (TCL application). It is the responsibility of the user to ensure that the combined performance of the TCL application and the strategy is acceptable.**

**Configuration:** The XNC part (TCL application) is configured using the TCLTool2 which runs within SET. This creates the XNC program file which can be downloaded using TCLTool2 or SET. TCLTool2 also creates an XNP file which defines the inputs and outputs required by the TCL application.

The device part of the IQ3/XNC uses the standard IQ3 configuration modules plus the XNC interface module which are configured using SET. SET can import the XNP file and use it to populate the XNC interface module; the connections between the other strategy modules and the XNC interface module are then made using SET and become part of the strategy file. SET can download the strategy file to the IQ3 and can also upload the strategy file for backup purposes.

*Note that the XNC program file should be downloaded before the strategy file is downloaded.*

The strategy file and other configuration files (language, backdrop, and XNC) can be downloaded and uploaded across Ethernet, but only the strategy file can be downloaded or uploaded through the current loop Lan (IQ3/LAN only).

**Communications:** When operating as part of a Building Management System, the IQ3/XNC will be connected to other devices by means of the IQ system network. This means that information within the IQ3/XNC can be accessed using one of the IQ system supervisor programs, or passed to other IQ controllers using inter-controller communications, enabling the sharing of information across the whole system.

As with the standard IQ3, the controller creates its own internal Lan consisting of a node for its own controller, a CNC for its local supervisor (sCNC), a virtual CNC (vCNC, if configured), and a virtual INC (vINC, if acting as INC for its Ethernet Lan).

The XNC part is able to communicate directly by means of the following ports:

- Serial port (if /SER/... option fitted) set to either RS485 2 wire, RS485 4 wire, or RS232.

- Ethernet using TCP/IP

- CNC using IQ3's vCNC.

In order for the vCNC to operate, it must be configured using IPTool. The vCNC will normally be a member of an Ethernet Lan, but for IQ3./.../XNC/LAN/... it will be a member of a current loop Lan.

**Custom Language:** This is a programming language, based on BASIC, which is used to write the TCL application. Amongst other things it enables interfacing between the IQ System, and 3rd party systems. It is an enhanced version of the language used in NBOX/XNC220. A full description of the language can be found in the IQ3/XNC Interface Manual TE200918.

Note that the TCLTool2 and its documentation are only supplied to TIS (Trend Interface Specialists) employees who have completed the TCL training course.

**Modules:** The IQ3/XNC includes all the standard IQ3 modules, plus the XNC Interface module.

**XNC Interface Module:** The XNC Interface module contains the TCL Application, the Stores and SavedVars areas, and the inputs and outputs.

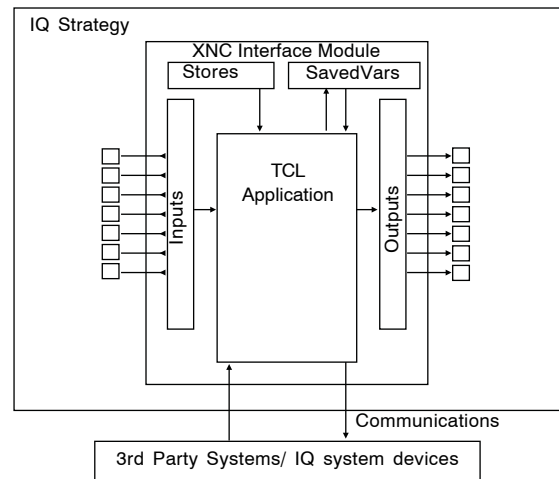

The **Stores** consist of up to 200 locations where user-defined constants are stored.

The **SavedVars area** consists of up to 100 locations where values, that may be written to and read from by the TCL application, will not be lost due to a power interruption.

The **Inputs** consist of up to 1000 points that can be connected to IQ3 module outputs using SET.

The **Outputs** consist of up to 1000 points that can be connected to IQ3 module inputs using SET,

The **Communications** defined above (Ethernet, RS232/485, or CNC) enable information to be read from and written to 3rd party systems and IQ system devices.

**XNC Interface Module (continued)**

The number of these items used by the TCL application affects the available capacity of the IQ3 for strategy modules. As explained in the IQ3 data sheet, the capacity is measured in brIQs.

The IQ3/XNC has a greater number of brIQs than the standard IQ3 as shown in the table below:

Type:		IQ3xcite	IQ3xact	IQ3xcite		
I/O max.:		0	12	16	96	128
IQ3	brigs max.	version not available	10,000	30,000	30,000	37,000
IQ3/XNC	brigs max.	45,000	20,000	version not available	45,000	version not available

The XNC interface module consumes 136 brIQs, and the TCL application consumes brIQs as follows:

- 5 brIQs :per store location, SavedVar location, input point, output point
- 20 brIQs :per line of TCL code

Full details of the XNC Interface module are given in IQ3 Configuration Manual TE200768.

**HARDWARE**

The standard IQ3 hardware is covered in the IQ3 data sheet, TA200505. Details of I/O modules and the /LAN/..., current loop Lan Auxiliary Board option, are also covered. The Serial Auxiliary Board option is only available as an option to the IQ3/XNC so is described here.

**Serial Auxiliary Board (/SER/... option)**

The IQ3../.../XNC/SER/... is supplied complete with a serial auxiliary board fitted in the auxiliary board slot, and with a special auxiliary board cover which enables access to the auxiliary board switches and connectors.

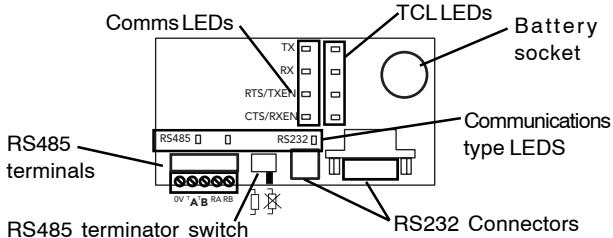

The auxiliary board also contains the circuit for a backup battery so it can also fulfil the function of the XCITE/BBC (battery board option). However, the CR2032 battery is not supplied, so must be purchased separately if a battery backup option is required.

The TCL application is able to select the communications type of the serial board to be either RS485 2 wire, RS485 4 wire or RS232. The RS485 4 wire setting may also be used for RS422.

Although the TCL application may switch between RS232 and RS485 communications, only one of these ports may be connected at one time in order to comply with Class B EMC emission standard (EN61000-6-3, residential, commercial, and light industrial environments)-see note in connections section.

**RS485 terminals:** The RS485 terminals are 5 wide. They are used for either RS485 2 wire or RS485 4 wire. They can also be used for an RS422 connection.

**RS485 2 wire:** RS485 2 wire is multidrop, and half duplex. There may be up to 32 devices on the bus. Note that only bus topology should be used (not loop or star), and any stubs should be kept short.

**RS485 4 wire:** RS485 4 wire is multidrop, and full duplex (although it may be used for half duplex signalling). There may be up to 32 devices on the bus.

The IQ3../.../XNC/SER/... is the master and other units on the bus are slaves .

Note that only bus topology should be used (not loop or star), and any stubs should be kept short.

**RS422:** RS422 is for a connection between 2 devices only, and full duplex (although it may be used for half duplex signalling).

**RS232 connectors:** There are two RS232 connectors, the 9 way D type plug, and an RJ11 socket. They are connected in parallel, and only one of these connectors should be used at a time. The maximum distance to the connected device is 30 m.

The RS232 can be used with or without limited handshaking (CTS/RTS) as specified by the TCL application. The connections are shown in the 'Connections' section below.

*Note that the 9 way D type terminal 4 (normally DTR) is held high so that the RS232 convertor can be powered from the connector (see Compatibility section below).*

**RS485 Terminator Switch:** The terminator switch is used to switch the two 120 ohm terminating resistors in or out of circuit. They should be switched into the circuit for RS485, and switched out for RS422 (not used for RS232).



**LEDs:** There are 11 LEDs arranged in the following groups:

**Communication type LEDs:** These consist of 2 RS485 LEDs and one RS232 LED. Using the TCL application the interface type may be set to either RS232, RS485 2 wire or RS485 4 wire.

**RS232 LED:** This green LED is illuminated for RS232 and extinguished for either type of RS485

**RS485 LEDs:** These two green LEDs operate as a pair. The left LED is illuminated on its own for RS485 2 wire. This indicates that the 2 terminals below it (TA, TB) should be used.

Both the left and right LEDs are illuminated for RS485 4 wire indicating that both pairs of terminals below the LEDs should be used (TA, TB, RA, RB). Both LEDs are extinguished for RS232.

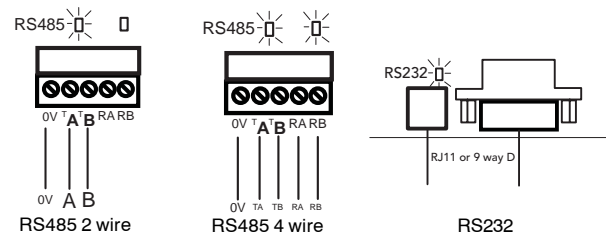

**Communications LEDs:** These 4 LEDs indicate the state of the communications through the serial interface:

**TX:** This yellow LED is illuminated when the interface is transmitting, and extinguished when it is receiving. It normally flashes as communications proceed.

**RX:** This yellow LED is illuminated when the interface is receiving, and extinguished when it is transmitting. It normally flashes as communications proceed.

Full details of RS485/RS422 wiring and connections are given in the IQ3 Configuration Manual TE200768 Pt. 1 section 4

**Serial Auxiliary Board (/SER/... option) (continued)**

**RTS/TXEN:** (green) For RS232 this LED is illuminated when the interface is Ready To Send and handshaking is selected. For RS485 4 wire, the LED is illuminated when the interface is enabled to Transmit. For RS485 2 wire the LED is illuminated when the interface is in transmit mode and extinguished when it is in receive mode.

**CTS/RXEN:** (green) For RS232 this LED is illuminated when the interface is Clear To Send and handshaking is selected. For RS485 4 wire, the LED is illuminated when the interface is enabled to Receive. For RS485 2 wire mode, the LED is permanently extinguished.

**TCL LEDs:** These 4 LEDs are switched on and off by the TCL code they are referenced 1 to 4, top to bottom. There is a space on the auxiliary board cover label on which to write the description of each LED's function.

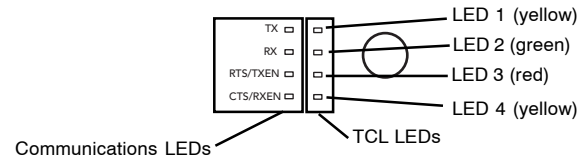
**COMPATIBILITY**

See IQ3 Data Sheet TA200505.

The TCL language is for this version of IQ3 (see specification).

If using a TCL application written for NBOX/XNC220, it can be modified to run on IQ3 using TCLTool2.

*Note that the RS232 to RS485 convertor used in the NBOX/XNC220/485 or the ENC2/S may be connected directly to the IQ3../.../XNC/SER/... RS232 connector without using the 9 way to 25 way D type cable supplied with these units. This facilitates the upgrading of NBOX/XNC220/485 or ENC2/S to IQ3../.../XNC/SER/... .*

**FIELD MAINTENANCE**

The IQ3/XNC requires no routine maintenance.

**DISPOSAL**

COSHH (Control of Substances Hazardous to Health - UK Government Regulations 2002) ASSESSMENT FOR DISPOSAL OF NODE CONTROLLER. The only part affected is the lithium battery which must be disposed of in a controlled way.

**RECYCLING.** 

All plastic and metal parts are recyclable. The printed circuit board may be sent to any PCB recovery contractor to recover some of the components for any metals such as gold and silver.

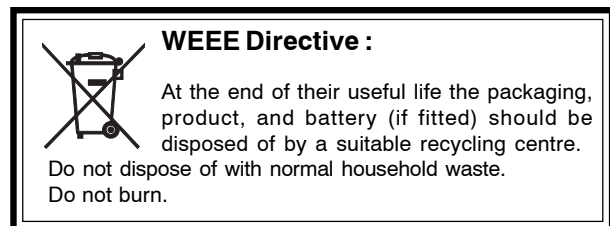

# INSTALLATION

The IQ3/XNC installation follows the same process as that described in the IQ3 data sheet except for the additional steps required for the TCL code and /SER/ interface. The procedure involves:

- mount the controller in position
- connect power, do not power up
- connect Ethernet if required
- connect RS232 if required (Supervisor/Tool PC, IQView, RD-IQ, or SDU-xcite)
- terminate the I/O channels, leave unconnected
- connect current loop Lan if required (IQ3../.../LAN only)
- connect additional RS232 or RS485 interface (IQ3../.../XNC/SER/... only)
- connect the I/O bus, if used (IQ3XCITE/96/.. only)
- mount and connect any I/O module (IQ3XCITE/96/.. only)
- set any I/O module address switches (IQ3XCITE/96/.. only)
- perform input channel linking
- fit battery option (XCITE/BBC) if required
- insert battery in auxiliary board if required (/LAN/ or /SER/ only)
- power up
- set terminator switch position (/SER/ and RS485 or RS422 only)

- set up IP address parameters (if Ethernet used) using IPTool
- setup Lan number using IPTool,
- setup Device address using address switch (IQ3../.../LAN) or by IPTool (IQ3s without current loop Lan auxiliary board)
- check Ethernet network if connected
- check current loop Lan network (IQ3../.../LAN only)
- write TCL code and create XNC TCL application file using TCLTool2
- configure the strategy, I/O modules used, and connections to XNC interface module (using SET)
- download TCL application (XNC file)
- download strategy file and other configuration files
- check BACnet communications using SET (IQ3/BAC only)
- check serial interface type and operation (/SER/ only)
- connect inputs and check operation
- connect outputs and check operation
- check web pages using a browser

This installation procedure is covered as follows: IQ3../.../XNC/... Installation Instructions TG200911 **plus either** IQ3xcite Installation Instructions TG200626, **or** IQ3xact Installation Instructions TG200766

# CONNECTIONS

The connections are described in the IQ3 data sheet except for the IQ3../.../XNC/SER/.. serial board connections as shown below.

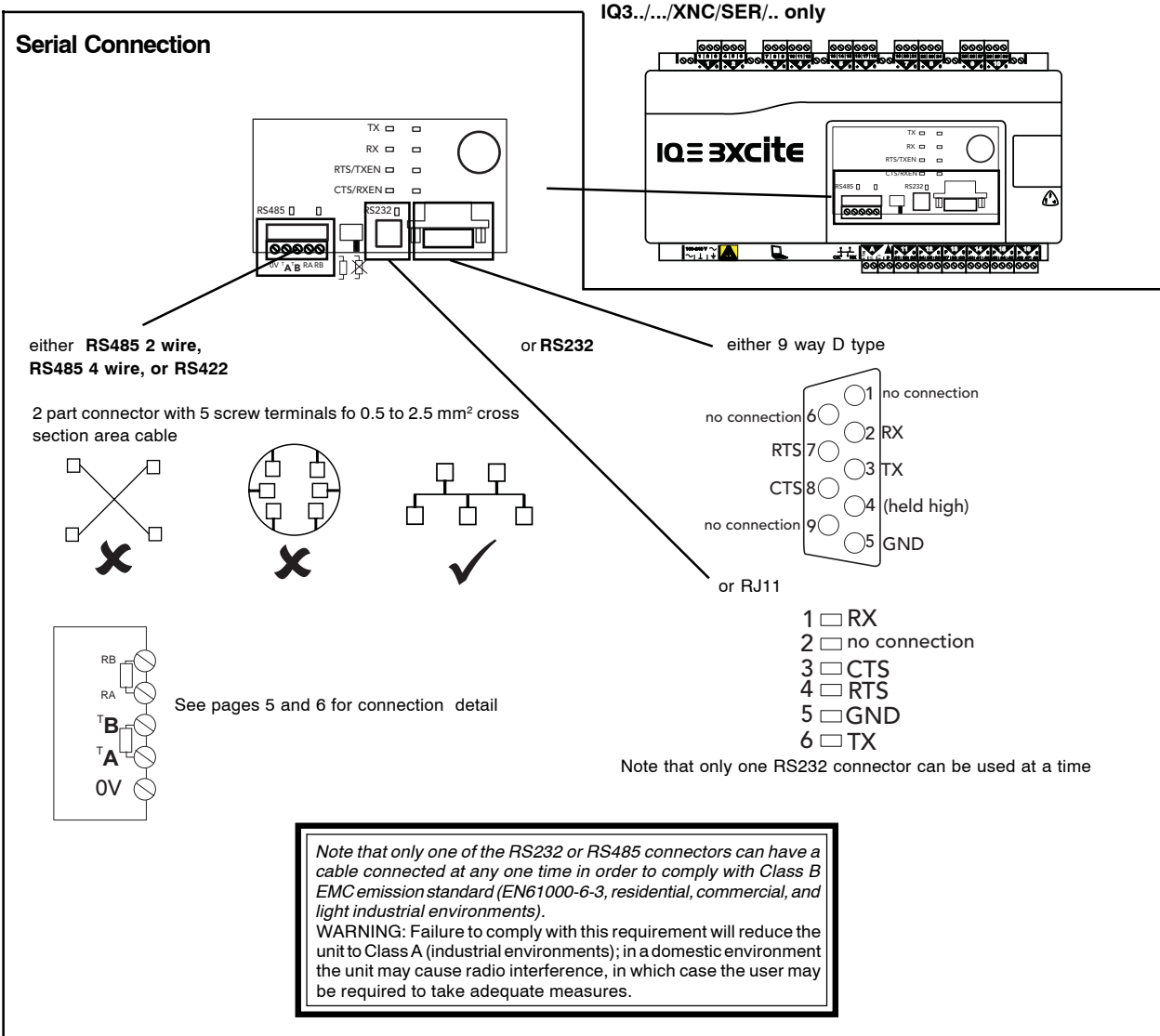

## ORDER CODES

A comprehensive list of order codes is given in the IQ3 data sheet.  
The following are the IQ3/XNC order codes.

	<b>Equivalent US code (UL rated)</b>	
<b>IQ3XCITE/000/XNC/LAN/UK/100-240:</b>		XNC, Zero I/O, with current loop Lan card, 100 to 240 V input power supply
<b>IQ3XCITE/000/XNC/SER/UK/100-240:</b>		XNC, Zero I/O, with serial card, 100 to 240 V input power supply
<b>IQ3XCITE/000/XNC/UK/100-240:</b>		XNC, Zero I/O, no auxiliary card, 100 to 240 V input power supply
<b>IQ3XCITE/000/XNC/LAN/UK/24:</b>	882001770	XNC, Zero I/O, with current loop Lan card, 24 V input power supply
<b>IQ3XCITE/000/XNC/SER/UK/24:</b>	882001800	XNC, Zero I/O, with serial card, 24 V input power supply
<b>IQ3XCITE/000/XNC/UK/24:</b>	882001820	XNC, Zero I/O, no auxiliary card, 24 V input power supply
<b>IQ3XACT/012/XNC/LAN/UK/100-240:</b>		XNC, 12 I/O points, non-expandable, with curr. loop Lan card, 100 to 240 V input power supply
<b>IQ3XACT/012/XNC/SER/UK/100-240:</b>		XNC, 12 I/O points, non-expandable, with serial card, 100 to 240 V input power supply
<b>IQ3XACT/012/XNC/UK/100-240:</b>		XNC, 12 I/O points, non-expandable, no auxiliary card, 100 to 240 V input power supply
<b>IQ3XACT/012/XNC/LAN/UK/24:</b>	882001840	XNC, 12 I/O points, non-expandable, with current loop Lan card, 24 V input power supply
<b>IQ3XACT/012/XNC/SER/UK/24:</b>	882001850	XNC, 12 I/O points, non-expandable, with serial card, 24 V input power supply
<b>IQ3XACT/012/XNC/UK/24:</b>	882001860	XNC, 12 I/O points, non-expandable, no auxiliary card, 24 V input power supply
<b>IQ3XCITE/096/XNC/LAN/UK/100-240:</b>		XNC, 96 I/O points, expandable, with current loop Lan card, 100 to 240 V input power supply
<b>IQ3XCITE/096/XNC/SER/UK/100-240:</b>		XNC, 96 I/O points, expandable, with serial card, 100 to 240 V input power supply
<b>IQ3XCITE/096/XNC/UK/100-240:</b>		XNC, 96 I/O points, expandable, no auxiliary card, 100 to 240 V input power supply
<b>IQ3XCITE/096/XNC/LAN/UK/24:</b>	882001780	XNC, 96 I/O points, expandable, with current loop Lan card, 24 V input power supply
<b>IQ3XCITE/096/XNC/SER/UK/24:</b>	882001790	XNC, 96 I/O points, expandable, with serial card, 24 V input power supply
<b>IQ3XCITE/096/XNC/UK/24:</b>	882001810	XNC, 96 I/O points, expandable, no auxiliary card, 24 V input power supply
<b>BACnet versions</b>		
<b>IQ3XCITE/000/XNC/LAN/UK/BAC/100-240:</b>		XNC, Zero I/O, with current loop Lan card, 100 to 240 V input power supply
<b>IQ3XCITE/000/XNC/SER/UK/BAC/100-240:</b>		XNC, Zero I/O, with serial card, 100 to 240 V input power supply
<b>IQ3XCITE/000/XNC/UK/BAC/100-240:</b>		XNC, Zero I/O, no auxiliary card, 100 to 240 V input power supply
<b>IQ3XCITE/000/XNC/LAN/BAC/UK/24:</b>	882001771	XNC, Zero I/O, with current loop Lan card, 24 V input power supply
<b>IQ3XCITE/000/XNC/SER/BAC/UK/24:</b>	882001801	XNC, Zero I/O, with serial card, 24 V input power supply
<b>IQ3XCITE/000/XNC/UK/BAC/24:</b>	882001821	XNC, Zero I/O, no auxiliary card, 24 V input power supply
<b>IQ3XACT/012/XNC/LAN/UK/BAC/100-240:</b>		XNC, 12 I/O points, non-expandable, with curr. loop Lan card, 100 to 240 V input power supply
<b>IQ3XACT/012/XNC/SER/UK/BAC/100-240:</b>		XNC, 12 I/O points, non-expandable, with serial card, 100 to 240 V input power supply
<b>IQ3XACT/012/XNC/UK/BAC/100-240:</b>		XNC, 12 I/O points, non-expandable, no auxiliary card, 100 to 240 V input power supply
<b>IQ3XACT/012/XNC/LAN/UK/BAC/24:</b>	882001841	XNC, 12 I/O points, non-expandable, with current loop Lan card, 24 V input power supply
<b>IQ3XACT/012/XNC/SER/UK/BAC/24:</b>	882001851	XNC, 12 I/O points, non-expandable, with serial card, 24 V input power supply
<b>IQ3XACT/012/XNC/UK/BAC/24:</b>	882001861	XNC, 12 I/O points, non-expandable, no auxiliary card, 24 V input power supply
<b>IQ3XCITE/096/XNC/LAN/UK/BAC/100-240:</b>		XNC, 96 I/O points, expandable, with current loop Lan card, 100 to 240 V input power supply
<b>IQ3XCITE/096/XNC/SER/UK/BAC/100-240:</b>		XNC, 96 I/O points, expandable, with serial card, 100 to 240 V input power supply
<b>IQ3XCITE/096/XNC/UK/BAC/100-240:</b>		XNC, 96 I/O points, expandable, no auxiliary card, 100 to 240 V input power supply
<b>IQ3XCITE/096/XNC/LAN/BAC/UK/24:</b>	882001781	XNC, 96 I/O points, expandable, with current loop Lan card, 24 V input power supply
<b>IQ3XCITE/096/XNC/SER/BAC/UK/24:</b>	882001791	XNC, 96 I/O points, expandable, with serial card, 24 V input power supply
<b>IQ3XCITE/096/XNC/UK/BAC/24:</b>	882001811	XNC, 96 I/O points, expandable, no auxiliary card, 24 V input power supply
The USA versions are identified in Trend UK by replacing /UK/ in the order codes with /USA/UL/ e.g.:		
<b>IQ3XCITE/096/XNC/USA/UL/BAC/24:</b>		XNC, 96 I/O points, expandable, no auxiliary card, 24 V power supply, BACnet option. UL rated.

## SPECIFICATIONS

See IQ3 data sheet, TA200505, for specifications except for serial auxiliary board as below:

/SER/...

<b>Serial interface type</b>	:set to RS485 2 wire, RS485 4 wire or RS232 by TCL application (RS485 4 wire also covers RS422)
RS485 2 wire	:2 wires plus 0 V return, multidrop half duplex. Switch on integral terminator
RS485 4 wire	:4 wires plus 0 V return, multidrop full duplex. Switch on integral terminators
RS485 (2/4 wire)	:Terminate at both ends of bus with 120 ohm (not on intermediate devices). 32 devices maximum.
RS422	:4 wires to single device full duplex. Switch off integral terminators. Fit 100 ohm terminators to receivers.
RS485/422	:Recommend continuous 0 V return, but use separate proper earths on long runs. 24 AWG cable, max length 1200 m. On long runs external to a panel, isolation and lightning protection may be required.
Battery option	:Battery socket for CR2032 3 V lithium button cell. On board 'supercap' supports clock for up to 6 days in case of power failure but battery will support it for several years.

*Note that if the battery option is required the battery cell must be purchased separately.*

### Connectors

RS485	:5 wide 2 part screw terminals for 0.5 to 2.5 mm <sup>2</sup> cross section area cables.
RS232	:RJ11 socket or 9 way D type plug

### Indicators

Communications type LEDs

<b>RS485</b> (left LED)	:( green) ON for RS485, OFF for RS232
<b>RS485</b> (right LED)	:(green) ON for RS485 4 wire only. OFF for RS232. (RS485 4 wire also covers RS422.)
<b>RS232</b>	:(green) ON for RS232, OFF for RS485

Communication LEDs

<b>TX</b>	:(yellow) Flashes ON while sending communications
<b>RX</b>	:(yellow) Flashes ON while receiving communications
<b>RTS/TXEN</b>	:(green) ON when interface ready to transmit (for RS232 also only if handshaking is selected by TCL application). For RS485 2 wire, OFF indicates interface is in receive mode.
<b>CTS/RXEN</b>	:(green) ON when interface ready to receive (for RS232 also only if handshaking is selected by TCL application). Not used for RS485 2 wire.
TCL LEDs	:Driven from TCL application

<b>TCL LED1</b>	:(yellow)
<b>TCL LED2</b>	:(green)
<b>TCL LED3</b>	:(red)
<b>TCL LED4</b>	:(yellow)

Version

Firmware	:This document covers
/SER/ Board	:IQ3../.../XNC/... v2.0
	:AM105995 v1

Please send any comments about this or any other Trend technical publication to [techpubs@trendcontrols.com](mailto:techpubs@trendcontrols.com)

© 2008 Honeywell Technologies Sàrl, ECC Division. All rights reserved. Manufactured for and on behalf of the Environmental and Combustion Controls Division of Honeywell Technologies Sàrl, Ecublens, Route du Bois 3, Switzerland by its Authorized Representative, Trend Control Systems Limited.

Trend Control Systems Limited reserves the right to revise this publication from time to time and make changes to the content hereof without obligation to notify any person of such revisions or changes.

### Trend Control Systems Limited

P.O. Box 34, Horsham, West Sussex, RH12 2YF, UK. Tel:+44 (0)1403 211888 Fax:+44 (0)1403 241608 [www.trend-controls.com](http://www.trend-controls.com)

### Trend Control Systems USA

6670 185th Avenue NE, Redmond, Washington 98052, USA. Tel: (425)897-3900, Fax: (425)869-8445 [ntc.novarcontrols.com](mailto:ntc.novarcontrols.com)