

## IQL15+/xxx Standard Strategies

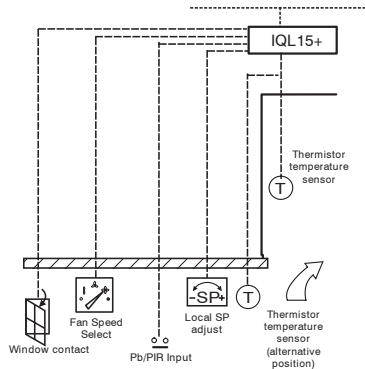

### IQL15+/... standard strategies inputs (common to all strategies)



### IQL15+/.../AR2 (Airside, Raise/Lower - Floating Point) outputs

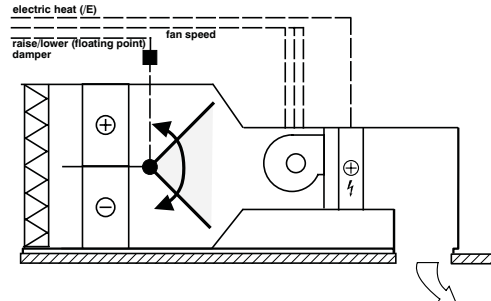

### IQL15+/.../WR2 (Water Side, Raise/Lower - Floating Point, 2 Pipe) outputs

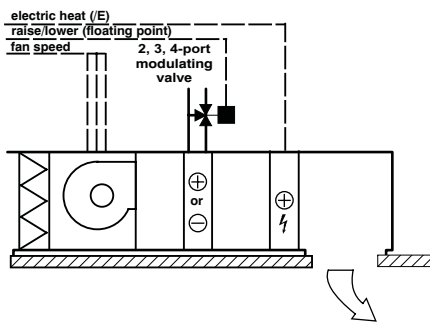

### IQL15+/.../WR4 (Water Side, Raise/Lower - Floating Point, 4 Pipe) outputs

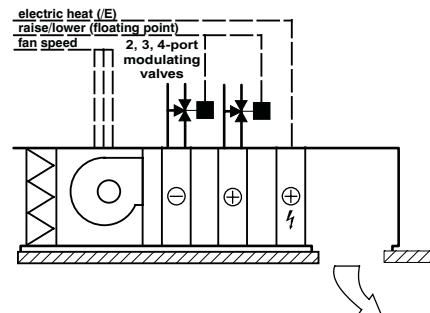

### IQL15+/.../WT2 (Water Side, Thermic, 2 Pipe) outputs

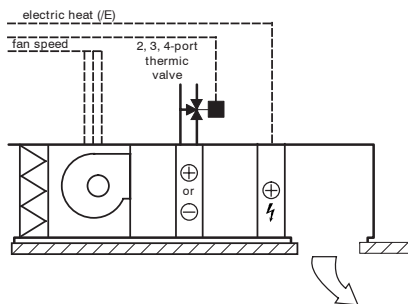

### IQL15+/.../WT4 (Water Side, Thermic, 4 Pipe) outputs

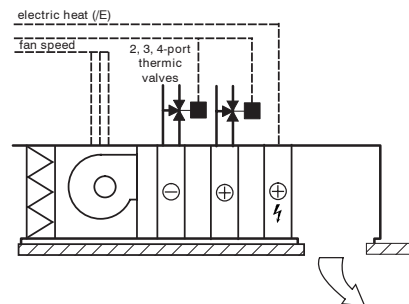

## Description

An IQL15+/xxx standard strategy controls a fan coil unit's heat/cool outputs, and 3 speed fan, in response to a thermistor temperature sensor with a local setpoint knob, a local switch input (pushbutton, or Passive Infra Red movement detector input), a window or alarm contact, and a fan speed select switch (off, low, medium, high, and auto). It has a relay output which can be used as an electric heater battery output (/E only), or as an auxiliary output (/AUX only) switched either locally by occupation status or remotely.

The heat/cool outputs vary with the strategy:

- /AR2 raise/lower (floating point) damper
- /WR2 raise/lower (floating point) heat or cool valve
- /WR4 raise/lower (floating point) heating and cooling valves
- /WT2 thermic heat or cool valve
- /WT4 thermic heating and cooling valves

## Features

- Fan speed control with manual override
- Electric heater (/E only) or Auxiliary Relay output (/AUX only)
- Range of heating and cooling outputs
- Local setpoint adjustment
- Window contact, pushbutton, or occupancy detector override
- Compatible with RD-IQL room display
- \*Conforms to LONMARK® profile 8501
- \*\*eu.bac certified
- \* Note that LONMARK certification does not apply to custom strategies.
- \* Note that eu.bac certification only applies to /UK/, /WR2 and /WR4 strategies

CONNECTIONS

Inputs

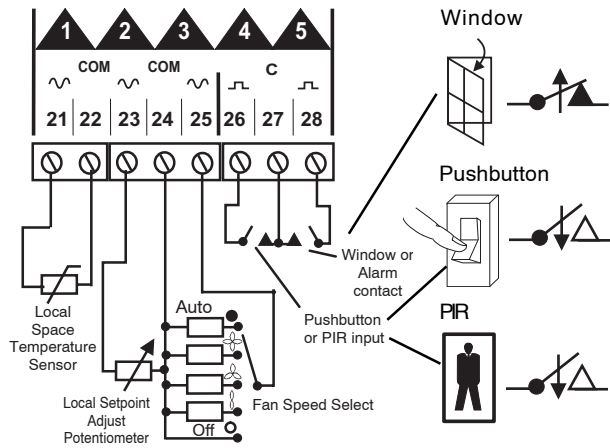

All strategies have the same inputs. The inputs (except for the Window Contact, IN5) can be provided by the following IQ system products:

- TB/TS space temperature sensor,
- TB/TS/K TB/TS plus setpoint adjustment,
- TB/TS/KE TB/TS/K plus occupation override pushbutton,
- TB/TS/KEF TB/TS/KE plus fan speed select switch.

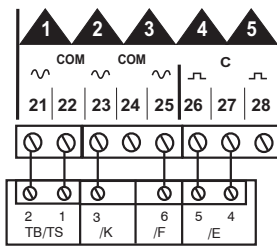

RD-IQL, Room Display, connects using one input (IN4) and has options:

**RD-IQL/K:** includes space temperature sensor with setpoint adjustment. If a setpoint adjust is required the RD's potentiometer must be used (not IN2). A separate sensor connected to IN1 may be used instead of the RD's; this is achieved by maintaining the original sensor type for IN1. There will be no PIR/pushbutton input. A fan speed switch connected to IN3 may be used.

**RD-IQL/KOS:** RD-IQL/K plus occupation override pushbutton and occupation status display. It has the same limitations as RD-IQL/K but there is now a pushbutton input.

**RD-IQL/KOSF:** RD-IQL/KOS plus fan speed select switch and display. It has the same limitations as RD-IQL/KOS. A separate fan speed switch connected to IN3 may be used instead of the RD's by maintaining the original sensor type for IN3.

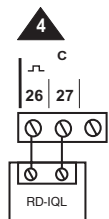

Note that the IQL15+ must be configured using text communications to use the RD-IQL. The settings are listed in the 'Using RD-IQL' section, p18.

Outputs

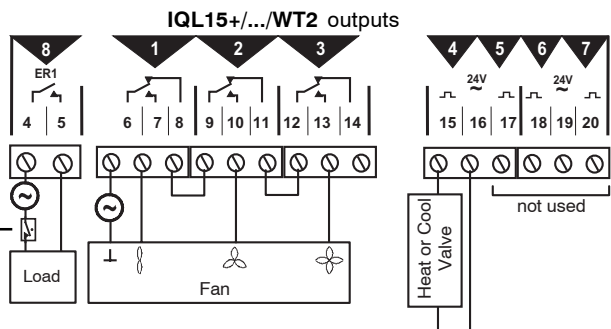
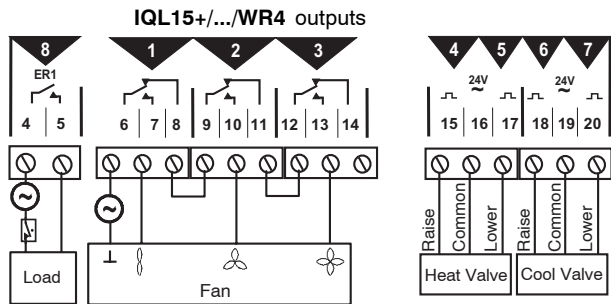
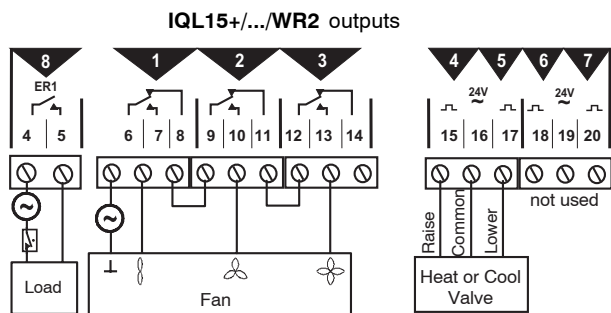
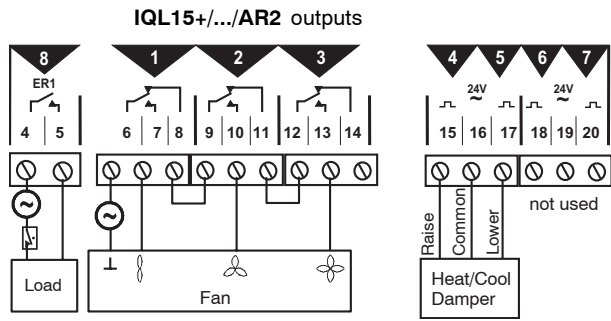

Note that a thermal cutout should be fitted in the supply to an electric heater (IQL15+/E/... strategies only)

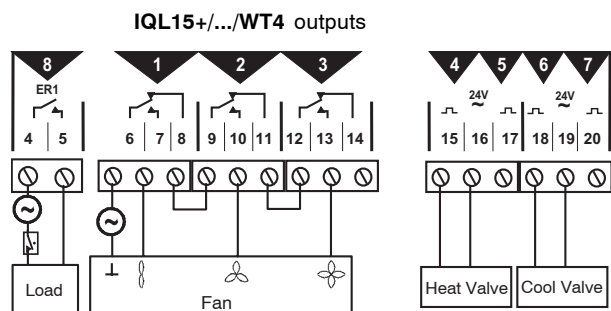

## FUNCTIONALITY

The IQL15+ functionality is described in the IQL15+ data sheet TA200341. This data sheet describes the additional functionality present when the controller is running a standard strategy.

### Real Inputs

The following real sensors and digital inputs are connected to the input channels and their values can be monitored by text comms (including IC Comms). The inputs IN1 to IN4 can be provided by the RD-IQL/KOSF Room Display connected to IN4:

#### Real Sensors

**S9 (IN1):** Local Space Temp, the thermistor temperature sensor reading.

**S10 (IN2):** Local SP Adjust, the local setpoint adjustment potentiometer value scaled in the range 0 to 1, and added to the default S10 offset of -1/2 to produce the range -1/2 to +1/2. This generates a setpoint trim in the range (/UK/: -1 °C to +1 °C, /USA/UL/: -1 °F to +1 °F) when the default Offset Range (K15) of (/UK/: 2 °C, /USA/UL/: 2 °F) is used.

**S11 (IN3):** Local Fan Speed, the adjustment switch setting converted to a value: 0 (off), 1 (low), 2 (medium), 3 (high), or 4 (auto).

#### Real Digital Inputs

**I9 (IN4):** Pushbutton PIR, this input can be either a Pushbutton or a PIR (Passive Infra Red occupation detector) which closes for a least 1 second when the occupation override is required. O=Pb I=PIR, W6 selects whether the input is a pushbutton or PIR input.

**PIR (W6=I):** A contact closure (people present) effectively switches the unit from Standby into Bypass while people are present plus for the Pb PIR Run On time (G1(F), default 30 mins). The Bypass state also produces Unit Occupied state within the unit.

**Pushbutton (W6=O):** A contact closure switches the state from any occupation state into Bypass for Pb PIR Run On time (G1(F), default 30 mins). The Bypass state also produces Unit Occupied state within the unit.

**I10 (IN5):** Window Contact; this input can be an alarm contact (e.g. filter blocked) or window contact which opens when the window is opened. If Window Mode is selected by W5, opening the window will cause the occupancy state to change to unoccupied, disable cooling, only allow sub-zero heating, and will disable fabric protection during non-occupation.

### Outputs

**Channels 1, 2, 3 (OUT1, terminals 6,7,8; OUT2, terminals 9, 10, 11; OUT3, terminals 12, 13, 14):** These three changeover relay outputs are used to select fan speeds Low, Medium, and High respectively. The fan is normally off during non-occupation unless there is a heating demand for fabric protection or the electric heater (/E only) is on or cooling during non-occupation. The fan is on during occupation (including bypass and standby states) if in Auto.

**Channels 4, 5 (OUT4, 5, terminals 15, 16, 17):** Two triac outputs.

**Channels 6, 7 (OUT6, 7, terminals 18, 19, 20):** Two triac outputs.

**Channel 8 (OUT8 terminals 4, 5: /E, this relay is used to drive an electric heater. This is used to supplement the heating if the heating demand is above 99% and if the electric heater is enabled (W3=O). If /AUX this relay is used as an auxiliary output contact. If W3=O (default), the output is controlled remotely by W9, but if W3=I, the relay is energised when the Unit Occupied status is true.**

| Item                  | IN  | Node  | Description   | Units           | /UK/    |                      |     | /USA/UL/ |                      |     | Meaning   | nv name                                       |                |
|-----------------------|-----|-------|---|-----------------|---------|----------------------|-----|----------|----------------------|-----|---|---|----------------|
|                       |     |       |   |                 | Default | Default range Bottom | Top | Default  | Default range Bottom | Top |   |   |                |
| <b>Sensors</b>        |     |       |   |                 |         |                      |     |          |                      |     |   |   |                |
| Intern.               | S1  | A1    | Space Temp  | DegC            | 20      |                      |     | DegF     | 68                   |     |   | nvoSpaceTemp                                  |                |
|                       | S2  | A2    | Setpoint  | DegC            | 20      |                      |     | DegF     | 68                   |     |   | nvoEffectSetPt                                |                |
|                       | S3  | A3    | Occupancy   | -               | 0       |                      |     | -        | 0                    |     | 0(Occupied), 1(Unocc), 2(Bypass), 3(Standby)                            | nvoOccCmd                                     |                |
|                       | S4  | A4    | Heating Demand  | %               |         |                      |     | %        |                      |     |   | nvoHeatOutput                                 |                |
|                       | S5  | A5    | Cooling Demand  | %               |         |                      |     | %        |                      |     |   | nvoCoolOutput                                 |                |
|                       | S6  | A6    | Fan Speed   | -               |         |                      |     | -        |                      |     | 0 (off), 1 (low), 2 (med), 3 (high)                                     | nvoFanSpeed                                   |                |
|                       | S7  | A7    | Effect Fan Spd  | -               |         |                      |     | -        |                      |     | 0 (off), 1 (low), 2 (med), 3 (high), 4 (auto)                           | nvoA7   |                |
| <b>Real</b>           |     |       |   |                 |         |                      |     |          |                      |     |   |   |                |
|                       | S9  | IN1   | A9  | Local SpaceTemp | DegC    |                      |     | DegF     |                      |     | thermistor  |   |                |
|                       | S10 | IN2   | A10   | Local SP Adjust | Knob    |                      |     | Knob     |                      |     | -1/2 to +1/2 (potentiometer)  |   |                |
|                       | S11 | IN3   | A11   | Local Fan Speed | -       |                      |     |          |                      |     | switched resistance gives 0 (off), 1 (low), 2 (med), 3 (high), 4 (auto) |   |                |
| <b>Knobs</b>          |     |       |   |                 |         |                      |     |          |                      |     |   |   |                |
|                       | K1  | A17   | Remote Setpoint                                       | DegC            | 22      | 18                   | 24  | DegF     | 72                   | 64  | 76  | nviSetPoint                                   |                |
|                       | K2  | A18   | RemoteSpaceTemp                                       | DegC            | 20      | 0                    | 30  | DegF     | 68                   | 32  | 86  | nviSpaceTemp                                  |                |
|                       | K3  | A19   | OCC Deadbnd   | DegC            | 4       | 0.5                  | 4   | DegF     | 2                    | 1   | 4   | nviA19  |                |
|                       | K4  | A20   | Standby Deadbnd                                       | DegC            | 8       | 1                    | 8   | DegF     | 4                    | 2   | 6   | nviA20  |                |
|                       | K5  | A21   | NOCC Deadbnd  | DegC            | 27      | 8                    | 27  | DegF     | 22                   | 15  | 36  | nviA21  |                |
|                       | K6  | A22   | Remote Occ  | -               | 0       | 0                    | 3   | -        | 0                    | 0   | 3   | 0(Occupied), 1(Unocc), 2(Bypass), 3(Standby)  | nviOccCmd      |
|                       | K7  | A23   | Remote Fan Spd  | -               | 4       | 0                    | 4   | -        | 4                    | 0   | 4   | 0 (off), 1 (low), 2 (med), 3 (high), 4 (auto) | nviFanSpeedCmd |
|                       | K8  | A24   | Remote SP Offset                                      | DegC            | 0       | -10                  | 10  | DegF     | 0                    | -10 | 10  | nviSetptOffset                                |                |
|                       | K15 | A31   | Offset Range  | DegC            | 2       | 1                    | 10  | DegF     | 2                    | 1   | 10  |   |                |
| <b>Switches</b>       |     |       |   |                 |         |                      |     |          |                      |     |   |   |                |
|                       | W1  | B18.0 | O=4Pipe I=2Pipe                                       | *               |         |                      |     | *        |                      |     |   | nviB18_0                                      |                |
|                       | W2  | B18.1 | Summer Mode   | O               |         |                      |     | O        |                      |     | O=Winter (heat only)  | nviB18_1                                      |                |
|                       | W3  | B18.2 | Elec Disable (/E only)<br>Aux Rly - local (/AUX only) | O               |         |                      |     | O        |                      |     | I=Disable Elec<br>I=Local   | nviB18_2                                      |                |
|                       | W4  | B18.3 | O=Water I=Air   | *               |         |                      |     | *        |                      |     |   | nviB18_3                                      |                |
|                       | W5  | B18.4 | Window Mode   | O               |         |                      |     | O        |                      |     | I=Window mode   | nviB18_4                                      |                |
|                       | W6  | B18.5 | O=Pb I=PIR  | O               |         |                      |     | O        |                      |     | I=PIR   | nviB18_5                                      |                |
|                       | W7  | B18.6 | Frost Condition                                       | O               |         |                      |     | O        |                      |     | I=Frost Condition   | nviB18_6                                      |                |
|                       | W8  | B18.7 | Remote Shutdown                                       | O               |         |                      |     | O        |                      |     | I=Shutdown  | nviB18_7                                      |                |
|                       | W9  | B19.0 | Remote Aux Relay (AUX only)                           | O               |         |                      |     | O        |                      |     | I=Relay energised   |   |                |
| <b>Digital Inputs</b> |     |       |   |                 |         |                      |     |          |                      |     |   |   |                |
| Intern.               | I1  | B1.0  | Fan Enabled   |                 |         |                      |     | I (Occ)  |                      |     |   | nvoB1_0                                       |                |
|                       | I2  | B1.1  | Unit Occupied   |                 |         |                      |     | O        |                      |     | (default from K6)   | nvoB1_1                                       |                |
|                       | I3  | B1.2  | Unit Unoccupied                                       |                 |         |                      |     | O        |                      |     | (default from K6)   | nvoB1_2                                       |                |
|                       | I5  | B1.4  | Unit in Standby                                       |                 |         |                      |     | O        |                      |     | (default from K6)   | nvoB1_4                                       |                |
| <b>Real</b>           |     |       |   |                 |         |                      |     |          |                      |     |   |   |                |
|                       | I9  | IN4   | B2.0  | Pushbutton PIR  |         |                      |     |          |                      |     | (contact closes =I)   |   |                |
|                       | I10 | IN5   | B2.1  | Window Contact  |         |                      |     |          |                      |     | (Window open = contact open =O)   |   |                |

\* Default setting depends on strategy

Strategy Items

Channels 4, 5 are used by driver module 2, and channels 6, 7 are used by driver module 3. The types of these driver modules are set according to the strategy requirements as shown in the table below. They can be changed after installation by text comms - see Changing the Strategy section .

| Channel | OUT | Strategies             |                          |                  |                          |                  |
|---------|-----|------------------------|--------------------------|------------------|--------------------------|------------------|
|         |     | AR2                    | WR2                      | WR4              | WT2                      | WT4              |
| 4       | 4   | Raise heat/cool damper | Raise heat or cool valve | Raise heat valve | Drive heat or cool valve | Drive heat valve |
| 5       | 5   | Lower heat/cool damper | Lower heat or cool valve | Lower heat valve | not used                 | not used         |
| 6       | 6   | not used               | not used                 | Raise cool valve | not used                 | Drive cool valve |
| 7       | 7   | not used               | not used                 | Lower cool valve | not used                 | not used         |

**FUNCTIONALITY** (continued)**Internals**

The following internal sensors and digital inputs are generated by the strategy and their values can be monitored by text comms (including IC Comms) and LONWORKS® comms (using network variables). Some can be monitored using display and directory modules (e.g. using IQView):

**Internal Sensors**

**S1:** The Space Temperature used by the strategy. It is normally taken from the Local SpaceTemp (IN1), but if there is a sensor fault (read or out of limits) it will use the RemoteSpaceTemp (K2). It will also use the RemoteSpaceTemp if the RemoteSpaceTemp is bound to a LONWORKS sensor.

**Internal Sensors** (continued)

**S2:** The Setpoint used by the strategy. It is the setpoint set by the Remote Setpoint (K1) plus the trim generated by multiplying the Local SP Adjust (IN2), by the Offset Range (K15). If the Local SP Adjust has a fault (read or out of limits) it will use the Remote SP Offset (K8) as a trim. It will also use K8 if Remote SP Offset is bound to a LONWORKS sensor

**S3:** The Occupancy state of the IQL, in the range: 0(Occupied), 1(Unoccupied), 2(Bypass), 3(Standby). These states are defined below under Remote Occ (K6). The Remote Occ specifies the occupancy state. The PIR (I9) can override from Standby into Bypass; the Pushbutton can override from any state into Bypass. Within the unit Bypass produces the Occupied state. The Window Contact (I10) or the Remote Shutdown (W8) will override into Unoccupied

**S4:** The Heating Demand is the calculated requirement for heating (0 to 100%).

**S5:** The Cooling Demand is the calculated requirement for cooling (0 to 100%).

**S6:** The Fan Speed applied to the fan driver, in the range, 0 (off), 1 (low), 2 (medium), 3 (high). During Occupation it follows the Effect Fan Spd (S7) below, but when Auto is selected, it will normally be low speed and during periods of high heating or cooling demand, the fan speed will be increased to medium or high, if the demand stays high. During non-occupation, the fan will be off, unless fabric protection operates, or the electric heater is on or cooling down.

**S7:** The Effect Fan Spd (effective fan speed) is in range, 0 (off), 1 (low), 2 (medium), 3 (high), or 4(auto). It takes the value of Remote Fan Spd, (K7), unless Remote Fan Spd is 4 (auto - default) when it will take the value of Local Fan Speed (S11). The Effect Fan Spd can be sent by IC Comms to another IQL as its Remote Fan Spd (K7).

**Internal Digital Inputs**

**I1:** Fan Enabled, indicates that the Fan is Enabled (i.e. fan speed is not zero).

**I2:** Unit Occupied, indicates that the Unit is Occupied (out of box default). It will be true if the Unit is in Bypass or Occupied as dictated by the Remote Occ (K6), and by the Pushbutton or the PIR (I9). It is switched off into Unoccupied by Window Contact (I10), or Remote Shutdown (W8).

**I3:** Unit Unoccupied indicates that the Unit is Unoccupied as dictated by the Remote Occ (K6). The pushbutton can switch the unit from unoccupied to bypass state (equivalent to Unit Occupied), but the Window Contact (I10), or Remote Shutdown (W8) will override to unoccupied.

**I5:** Unit in Standby indicates the Unit is in Standby as dictated by the Remote Occ (K6). The pushbutton or the PIR will override to Bypass. Bypass is treated as Occupied within the unit. It is switched into Unoccupied by Window Contact (I10), or Remote Shutdown (W8).

**Adjustments**

The following switch and knob adjustments can be monitored and changed by text comms (including IC Comms), and by LONWORKS comms (using network variables). Some can be monitored using display and directory modules (e.g using IQView):

**Switches**

**W1:** This switch, O=4Pipe I=2Pipe is used to select the strategy type, either 2 pipe (W1=I) or 4 pipe (W1=O). Strategy selection is described in the Changing the Strategy section.

**W2:** This switch, Summer Mode, selects the output used to drive the single valve for 2 pipe strategies. If Winter mode is selected (W2=O, default), the valve is driven from the heating demand, and if Summer mode is selected (W2=I) the valve is driven from the cooling demand.

**W3:** If /E this switch, Elec Disable, disables the electric heater if set true (W3=I). If W3=O (default) the electric heater is enabled. If /AUX, this switch selects the local control of the auxiliary relay output (OUT8). If locally controlled (W3=I), the relay is energised when the Unit is Occupied. If W3=O (default), the output is controlled remotely by W9.

**W4:** This switch, O=Water I=Air, is used to select the strategy type, either Air (W4=I) or Water (W4=O). Strategy selection is described in the Changing the Strategy section.

**W5:** This switch, Window Mode, enables the Window Contact (IN5), if set true (W5=I). If W5=O (default) the Window Contact is disabled but can still be used to generate alarms.

**W6:** This switch, O=Pb I=PIR, selects whether the Pushbutton or PIR input is being used for IN4. If W6=I, PIR is selected, if W6=O (default) Pushbutton is selected.

**W7:** This switch, Frost Condition, forces the unit into a Frost Condition during non-occupation if set true (W7=I) and if running a Water side strategy (W4=O). During the frost condition the heating demand is set to 98%. If W7=O (default) the frost condition is turned off.

**W8:** This switch, Remote Shutdown, forces the unit into the Unoccupied state, disables cooling, only allows sub-zero heating, and disables fabric protection during non-occupation if set true (W8=I). If W8=O (default) the Remote Shutdown is turned off.

**Switches** (non LonWorks comms)

This switch can only be adjusted by text comms (including IC Comms), not LonWorks Comms.

**W9:** If /AUX, this switch, Remote Aux, controls the auxiliary relay remotely if W3=O (default). If W9=I the relay is energised.

**Knobs**

**K1:** This knob, Remote Setpoint (default = /UK/: 22 °C, /USA/UL: 72 °F), is combined with the Local Setpoint Adjust (IN2) to produce the Setpoint (S2). If the Local SP Adjust has an Outside Limits or Read alarm, or if the Remote SP Offset (K8) is bound to a LONMARK sensor (i.e. connected by LONWORKS communications to an output from another LONWORKS device), the Remote SP Offset is used to trim the setpoint instead of the Local SP Adjust.

**K2:** This knob, Remote Space Temp (default = /UK/: 20 °C, /USA/UL: 68 °F), is used instead of the Local Space Temp (S9) when S9 has an Outside Limits or Read alarm, or if the Remote Space Temp is bound to a LONMARK sensor (i.e. connected by LONWORKS communications to an output from another LONWORKS device).

**K3:** This knob, OCC Deadbnd (default = /UK/: 4 °C, /USA/UL: 2 °F), defines the difference between the heating and cooling setpoints during occupation.

**K4:** This knob, Standby Deadbnd (default = /UK/: 8 °C, /USA/UL: 4 °F) defines the difference between the heating and cooling setpoints during standby.

**K5:** This knob, NOCC Deadbnd (default = /UK/: 27 °C, /USA/UL: 22 °F) defines the difference between the heating and cooling setpoints during non-occupation.

**FUNCTIONALITY** (continued)

**Knobs** (continued)

**K6:** This knob, Remote Occ, (default = 0, Occupied) defines the unit's occupancy state: 0(Occupied), 1(Unoccupied), 2(Bypass), 3(Standby). It can be overridden into Bypass (equivalent to Occupied within the unit) from any occupation state by the Pushbutton or from Standby by the PIR. The state is overridden to Unoccupied by the Remote Shutdown (W8), or the Window Contact (IN5).

**Occupied:** The fan is on, if in auto, and the Cool outputs are enabled if the fan is on (Heat outputs are enabled anyway). The Occupation Deadband (default = /UK/: 4 °C, /USA/UL/: 2 °F) is used.

**Unoccupied:** Heating is enabled and the Non-occupied Deadband (default = /UK/: 27 °C, /USA/UL/: 22 °F) is used. The fan is normally off, but Fabric protection will bring it on. The Frost Condition W7 will override the heating to 98%. If the electric heater is brought on the fan always comes on. If the fan is on Cooling is enabled.

**Bypass:** This effectively produces the same state as occupied but it is intended to be used for a short time only. If the bypass state is produced (either by Remote Occ, K6, or by pushbutton or PIR) it will produce the occupied state inside the unit, although Occupancy (S3) will show the bypass state.

**Standby:** The fan and heat and cool outputs operate as for occupied. It is designed to reduce energy consumption in the zone (Standby Deadband defaults to /UK/: 8 °C, /USA/UL/: 4 °F). The unit is put back into occupation by PIR or pushbutton (using Bypass).

**K7:** This knob, Remote Fan Speed (default = 4, Auto), sets the fan speed in range: 0 (off), 1 (low), 2 (medium), 3 (high), or 4(auto). If set to a non-auto state it will override the Local Fan Speed (IN3). The fan will be switched off during non-occupation unless there is heating demand (fabric protection) or electric heater is on which both select low fan speed.

**K8:** This knob, Remote SP Offset (default = /UK/: 0 °C, /USA/UL/: 0 °F), is added to the Remote Setpoint (K1) instead of the Local SP Adjust (S10) if the Local SP Adjust has an Outside Limits or Read alarm, or if the Remote SP Offset (K8) is bound to a LONMARK sensor (i.e. connected by LONWORKS communications to an output from another LONWORKS device).

**Knobs (non LonWorks comms.)**

This knob can only be adjusted by text comms (including IC Comms), not LONWORKS comms:

**K15:** This knob, Offset Range (default = /UK/: 2°C, /USA/UL/: 2 °F), is used to define the range of the Local SP Adjust (IN2). The Local SP Adjust is scaled to give a value in the range -½ to +½. This is multiplied by the Offset Range to give the setpoint trim which is applied to the Remote Setpoint (K1) to produce the Setpoint (S2).

**Parameters**

The following parameters may be required to be changed by text comms:

**G1(F):** PIR/PB run on time (default 1800s = 30 mins). PIR detector or Pushbutton will override occupation state into occupied for this time.

**L1(G), L1(I):** The heating loop gain (default 30) and integral (default 30 mins) may need to be tuned for optimum performance.

**L2(G), L2(I):** The cooling loop gain (default -30) and integral (default 30 mins) may need to be tuned for optimum performance.

**G16(M)** - /UK/ only: The minimum on time (default 300 s = 5 mins) for the electric heater (/E only). The heater will be prevented from switching on again for this period after switch on.

**G16(F)** - /USA/UL/ only: The off delay (default 300 s = 5 mins) for the electric heater (/E only). The heater will be prevented from switching on again for this period.

**Text Comms**

The item values can be monitored or changed using text comms as described in the IQ System LONWORKS Products Engineering Manual (TE200292). The value of a sensor or knob is referred to by **V**, and the status of an input or switch is referred to by **S**. e.g. **S1(V)** gets value of S1, **W1(S=I)** sets switch 1 on. Some of the other parameters are:

Sensor, Knob, sWitch, Driver, Input, directory @: labels (\$)

Sensor, Knob: units (%)

Knob: (T)op of range, (B)ottom of range

Sensor: (O)ffset

Driver: (P)eriod, fullscale (D)rive time, t(Y)pe

Plot: (S)ensor number, (P)eriod (P=0: 1h, 1:15m, 2:24h, 3:1m, 4:5m, 6:20m, 7:30m, 8:6h)

Display ~: (I)tem

Loop: (I)ntegral, (G)ain, and (R)eschedule times

LoGic: o(N) delay, (M)inimum on time, o(F) delay

Function (rescale to, rescale from only): E, F, rescale limits

IC Comms N: remote device (A)ddress, attri(B)ute, remote la(N), (I)nterval, (S)ignificant change, source ite(M), d(E)stination module no., destination i(T)em

**Water Balancing**

The raise/lower (floating point) and time proportional outputs are set to 100% by sending the text comms message R(#=0). The output will remain set to drive at 100% (even if the power is switched off and on) until the IQL receives a Text comms message R(#=1).

*Note that raise/lower (floating point) drivers will remain in their positions when power is removed, whereas time proportional drivers will close.*

This enables the heating and cooling valves to be fully opened for balancing and flushing of a water side system (i.e. /WR2, /WR4, /WT2, /WT4 strategies). It should not be used on an airside system (e.g. /AR2).

*Note that time proportional outputs will not open together; the heat output will open first, then the cool output 10 seconds later, to reduce the peak current consumed.*

**LONWORKS Comms**

The nv name is the name given to the particular item for identification by a LONWORKS network management tool. The IQL can communicate with other LONMARK devices using Network Variables (NVs) if their items are bound together by the tool, see IQ System LONWORKS Products Engineering Manual (TE200292).

**Display and Directory modules**

There is 1 directory module with 6 display modules. See IQ System LONWORKS Products Engineering Manual for use of these modules.

| Directory | Label    | Display | Item               |
|-----------|----------|---------|--------------------|
| 1         | Overview | 1       | K1 Remote Setpoint |
|           |          | 2       | S1 Space Temp      |
|           |          | 3       | S4 Heating Demand  |
|           |          | 4       | S5 Cooling Demand  |
|           |          | 5       | S6 Fan Speed       |
|           |          | 6       | K6 Remote Occ      |

**Plot**

The single plot channel is set to plot the Space Temp sensor S1 at 15 min intervals (80 readings). It can be changed by text comms - see above.

## STRATEGY

### BRIEF DESCRIPTION

The strategy controls a fan coil unit with heat/cool outputs (dependent on strategy type), a 3 speed fan, and an electric heater (/E only), in response to a thermistor temperature sensor reading. A local setpoint adjustment can trim the setpoint. A window contact input and a pushbutton or PIR (Passive Infra Red movement detector) input can override the occupation state. A fan speed select switch can manually override the fan speed to off, low, medium or high, or set it back to auto.

The controller maintains the temperature of a space to the defined setpoint. The plant diagrams on the first page illustrate typical controller applications for the standard strategies available. The control is achieved by modulating the heat/cool output(s) based on the current space requirements.

The controller operates in either Occupied, Unoccupied, Bypass, or Standby modes as determined by the **Remote OCC** setting. The controller maintains the comfort level to a user-defined setpoint.

The controller controls the speed of the supply air fan. The fan will be running during occupation, and if there is a heating demand during non-occupation. While in auto the fan speed will be increased as the heating or cooling demand increases. During occupation the fan may be overridden from the fan speed select switch if the remote fan control is set to auto; this switch can override the fan to off, low, medium, or high and can return the fan to Auto control as defined previously.

During non-occupation the unit will detect the temperature falling below the required temperature and switch on the fan at low speed (**Fabric protection**).

Also during non-occupation the remote **Frost Condition** setting will override the heating to 98% (water side only, not /AR2).

The heating and cooling are enabled whenever the fan is running

The occupancy override pushbutton will switch the unit into bypass from any other occupation state. A PIR (occupation sensor) will switch the unit into bypass from standby. Within the unit bypass is effectively the same as occupied.

The Window Contact or the **Remote Shutdown** setting will set the unit into Unoccupied, disable cooling, only allow heating for sub-zero temperatures, and stop fabric protection.

For 2 pipe strategies the controller can control heating only or cooling only as defined by the **Summer Mode** setting; if set to Winter (O) the controller controls heating only.

When cooling, the cooling output is calculated by a proportional + integral control loop based on the space temperature and the cooling setpoint. As the temperature rises above the cooling setpoint the cooling output will be increased. The cooling output will be decreased as the temperature falls below the cooling setpoint. When unoccupied, the cooling setpoint will be increased.

When heating, the heating output is calculated by a proportional + integral control loop based on the space temperature and the heating setpoint. As the temperature falls below the heating setpoint the heating output will be increased. The heating output will be decreased as the temperature rises above the heating setpoint. When unoccupied, the heating setpoint will be decreased.

The actual cool and heat setpoints are set above and below the user-defined setpoint by half the current deadband. The deadband is increased during non-occupation by having different deadbands for the operating modes, i.e. **OCC Deadbnd** (used for Occupied and Bypass modes), **Standby Deadbnd**, and **NOCC Deadbnd**.

The electric heater (/E only) is used to supplement the heating as the demand rises to (/UK/: 3%, /USA/UL/: 99%) during occupation and non-occupation. During non-occupation it forces the fan on unless the fan is manually switched off, in which case the heating will be disabled.

The inputs (except for the window contact) can be provided by the IQ system TB/TS/KEF or RD-IQL/KOSF products. The RD-IQL/KOSF, Room Display, includes a space temperature sensor, local setpoint adjust increase and decrease buttons, an occupancy override button, and a fan speed select button. It can display either local temperature or setpoint, and fan and occupation state icons.

The **Local SP Adjust** and **Local Space Temp** inputs generate both Read and Outside Limits alarms. The read alarm indicates a problem with the controller, and the Outside Limits alarm indicates that the input signal is outside its expected range. An alarm message will be sent both when an alarm condition is detected and when it is cleared if the alarm is enabled by text comms. The Pushbutton PIR, and Window contact inputs can be enabled by text comms to generate alarms either on input contact closures or on openings.

The Auxiliary Relay output (/AUX only) is normally controlled by the **Remote Aux Rly** setting, but if **Aux Rly I=local** is set, it is energised when the unit is occupied.

This page is intentionally left blank

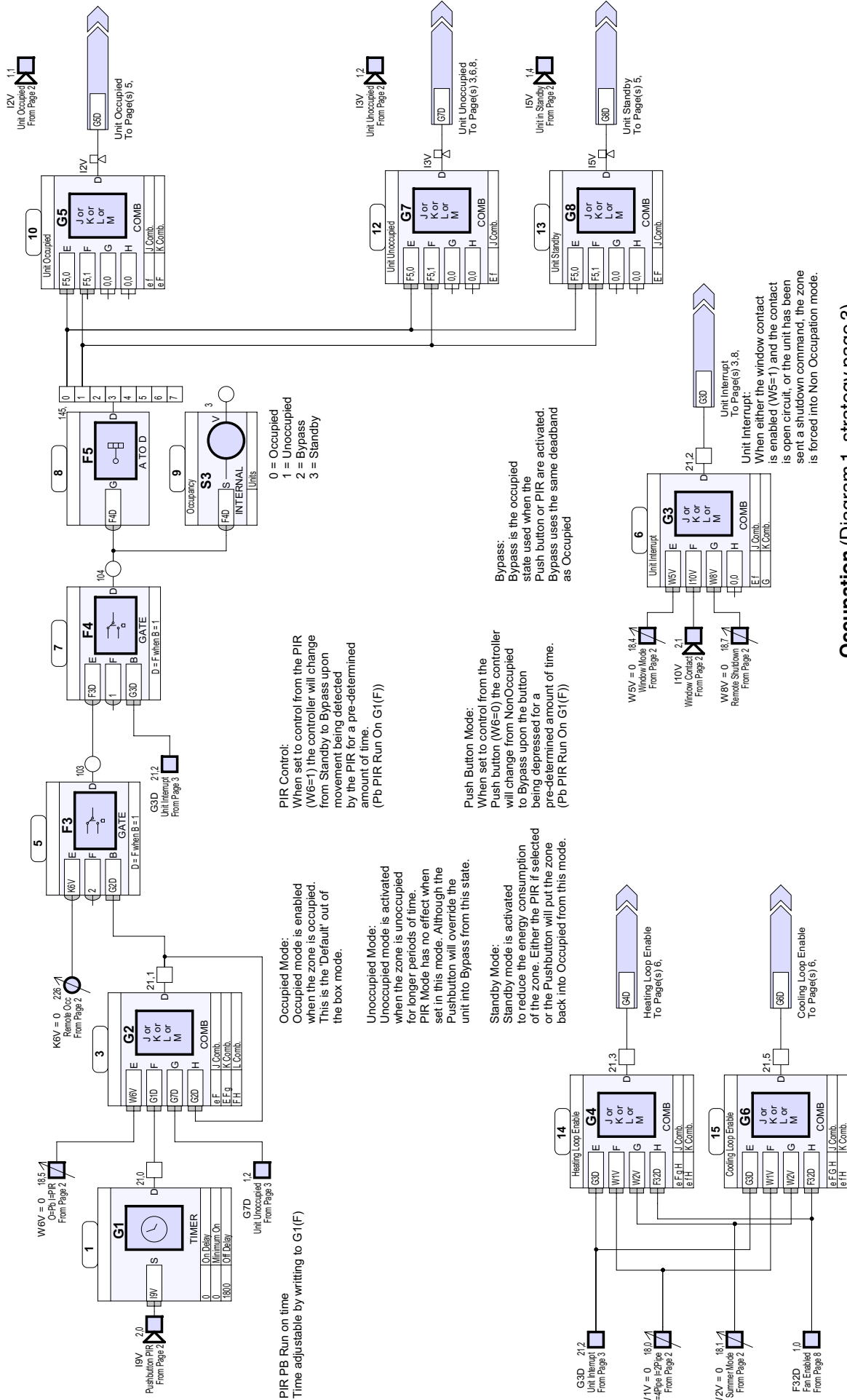

PIR Control:  
When set to control from the PIR (W6=1) the controller will change from Standby to Bypass upon movement being detected by the PIR for a pre-determined amount of time.  
(Pb PIR Run On G1(F))

Occupied Mode:  
When set to control from the PIR (W6=1) the controller will change from Standby to Bypass upon movement being detected by the PIR for a pre-determined amount of time.  
(Pb PIR Run On G1(F))

Unoccupied Mode:  
When set to control from the PIR (W6=1) the controller will change from Standby to Bypass upon movement being detected by the PIR for a pre-determined amount of time.  
(Pb PIR Run On G1(F))

Push Button Mode:  
When set to control from the PIR (W6=1) the controller will change from Standby to Bypass upon movement being detected by the PIR for a pre-determined amount of time.  
(Pb PIR Run On G1(F))

PIR PB Run on time  
Time adjustable by writing to G1(F)

Occupied Mode:  
When set to control from the PIR (W6=1) the controller will change from Standby to Bypass upon movement being detected by the PIR for a pre-determined amount of time.  
(Pb PIR Run On G1(F))

Unoccupied Mode:  
When set to control from the PIR (W6=1) the controller will change from Standby to Bypass upon movement being detected by the PIR for a pre-determined amount of time.  
(Pb PIR Run On G1(F))

Push Button Mode:  
When set to control from the PIR (W6=1) the controller will change from Standby to Bypass upon movement being detected by the PIR for a pre-determined amount of time.  
(Pb PIR Run On G1(F))

PIR PB Run on time  
Time adjustable by writing to G1(F)

Occupation (Diagram 1, strategy page 3)

## DETAILED DESCRIPTION

This section describes the strategy in detail.

*Note that the strategy diagrams have been produced with SET using standard IQ controller nodes. Other than the nodes associated with knobs, switches, sensors, and digital inputs, the remaining nodes are not implemented in the IQL so should be ignored; also note that knobs 1 to 16 are associated with nodes A17 to A32 which is different to normal IQs.*

### Occupation (Diagram 1, strategy page 3)

#### Summary

The controller operating mode is set by **Remote Occ** (K6) to Occupied, Unoccupied, Bypass, or Standby. The operating mode can be monitored by the **Occupancy** sensor (S3) or from the **Unit Occupied** (I2), **Unit Unoccupied** (I3), and **Unit in Standby** (I5) internal digital states.

The **Pushbutton** (I9) forces the unit into Bypass from any state for the **Pb PIR Run On** time (defined by G1(F), default 1800 s=30 mins). The **PIR detector** (I9) will override the unit from Occupied or Standby into Bypass for at least the **Pb PIR Run On** time (defined by G1(F), default 1800 s=30 mins). Within the unit, the Bypass condition is treated the same as Occupied.

The **Remote Shutdown** (W8) or **Window Contact** (I10) will override the unit into Unoccupied and disable the heating and cooling loops. Otherwise the heating loop is enabled if the fan is enabled during Winter for a 2 pipe strategy and all the time for a 4 pipe strategy, while the cooling loop is enabled if the fan is enabled, during summer for a 2 pipe strategy, and all the time for a 4 pipe strategy.

#### Detail

The Remote Occ state knob, K6, is set to either 0 (Occupied), 1 (Unoccupied), 2 (Bypass), or 3 (Standby) and is normally connected by way of F3 and F4 to the A to D module F5 whose input is monitored by the Occupancy Sensor S3. The 2 digital bits output by F5 are further decoded by logic modules G5, G7, and G8 respectively to produce the outputs, Unit Occupied (I2), Unit Unoccupied (I3) and Unit in Standby (I5).

Note that although S3 will monitor the separate Bypass (S3=2) state, G5 combines Bypass with the Occupied state so that within the rest of the strategy these two states are treated the same.

The combined Pushbutton PIR input (I9) initiates a pulse at the output of G1 for a minimum time defined by Pb PIR Run On time, G1(F), the off delay, (default 1800 s=30 mins). If O=Pb I=PIR, W6=O, the Pushbutton or PIR input (I9) is treated as Pushbutton, and G2 passes the pulse through to F3 which overrides the occupation state to 2 (Bypass). Thus the pushbutton will override the occupation state to Bypass (equivalent to Occupied in the strategy)

If O=Pb I=PIR, W6=I, the Pushbutton or PIR input (I9) is treated as PIR, and G2 allows the pulse through if the Unit is not Unoccupied (i.e. Occupied, Bypass or Standby). The PIR pulse will cause F3 to override the occupancy state to 2 (Bypass). Thus the PIR sensor will override the occupation state to Bypass (equivalent to Occupied in the strategy) from Occupied, Bypass, or Standby but will not affect an Unoccupied state.

The feedback from G2 output to its input H is used to ensure that the output of G2 selects Bypass for at least the time defined by G1(F) (in case another input changes state during this period). If either the Remote Shutdown W8 is present, or the Window Contact (I10) is open (and it is enabled by Window Mode W5=1), the output of G3 will override the occupancy state by way of F4 to Unoccupied, 1, and disable heating and cooling loops through G4 and G6 respectively.

With the output of G3 false and with the fan enabled, G4 enables the heating loop either for a 2 pipe strategy in Winter mode or for a 4 pipe strategy all the time. Also with the output of G3 false and with the Fan Enabled, G6 enables the cooling loop either for a 2 pipe strategy in Summer Mode or for a 4 pipe strategy all the time.

The Pushbutton PIR input (I9) and Window contact input (I10) can be enabled to generate alarm by text comms parameters I9(e), and I10(e) respectively.

e=0 or 1, alarm disabled

e=2 alarm enabled, required value =0

e=3 alarm enabled, required value =1

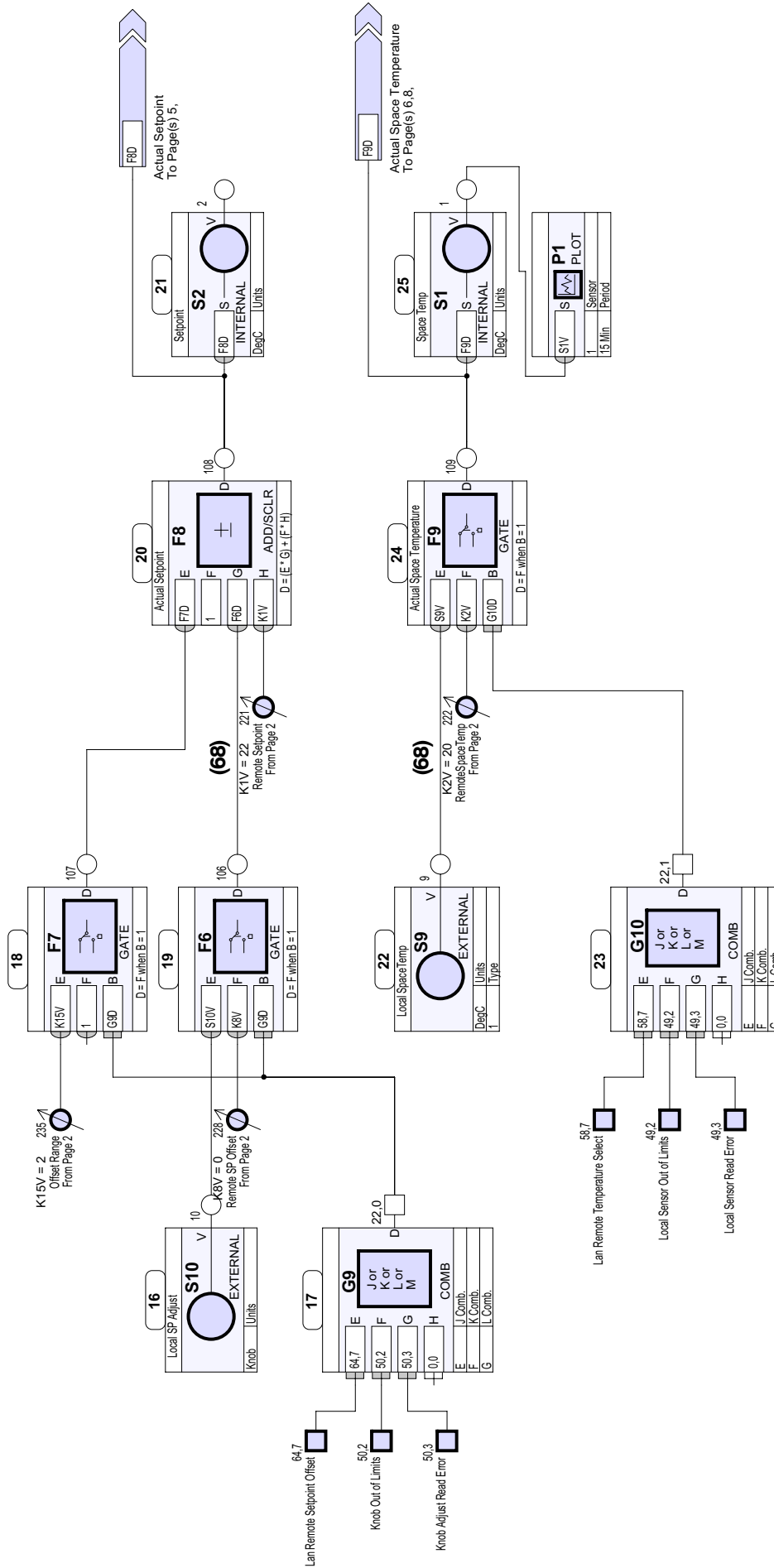

changes for the /USA/UL/ strategy shown in brackets

Setpoint and Details (Diagram 2, strategy page 4)

**Setpoint and Details (Diagram 2, strategy page 4)**

**Summary:**

**Setpoints**

The **Local SP Adjust** is scaled within the unit to produce a value in the range  $-\frac{1}{2}$  to  $+\frac{1}{2}$ . This is multiplied by the **Offset Range** (default /UK/: 2°C, /USA/UL/: 2 °F) to produce a trim (default /UK/: -1°C to +1°C, /USA/UL/: -1°F to +1°F). This trim is added to the **Remote Setpoint** (default /UK/: 22 °C, /USA/UL/: 72 °F) to produce the **Setpoint**.

$$\text{Setpoint} = \text{Local Setpoint Adjust} \times \text{Offset Range} + \text{Remote Setpoint}$$

If the **Remote SP Offset** is bound to a LONWORKS device, then the Remote SP Offset is added to the Remote Setpoint to produce the Setpoint. The Remote SP Offset is also used if Local SP Adjust has a Read or Out of Limits alarm condition

$$\text{Setpoint} = \text{Remote Setpoint Offset} + \text{Remote Setpoint}$$

**Space Temperature**

The **Space Temp** is normally the **Local Space Temp**, but if the **RemoteSpaceTemp** is bound to a LONWORKS device, it is used instead. The **RemoteSpaceTemp** is also used if the **Local Space Temp** has a Read or Out of Limits alarm condition.

**Detail:**

The real sensor S10 monitors the Local SP Adjust potentiometer (0 to 1) and adds offset (default  $-\frac{1}{2}$ ) to produce S10 output ( $-\frac{1}{2}$  to  $+\frac{1}{2}$ ). Function module F6 normally connects the adjustment to F8 where it is multiplied by the Offset Range K15 (default /UK/: 2 °C, /USA/UL/: 2 °F) and added to the Remote Setpoint K1 (default /UK/: 22 °C, /USA/UL/: 72 °F). This produces the actual setpoint monitored by Setpoint sensor S2.

If the Remote SP Offset K8 is bound to a LONWORKS device, then Lan Remote Setpoint Offset bit 64.7 is set true. If either this is true, or the Local Setpoint Adjust knob is Out of Limits or has a Read error, then the Remote SP Offset is gated through to F8 by F6, and the range from F7 is set to 1, with the result that F8 adds the Remote SP Offset to the Remote Setpoint. Thus Remote SP Offset K8 can either be a knob fail default, or it can be a value bound to a LONMARK device.

The Space Temp (S1) is normally the Local Space Temp (S9) by way of F9 but if the RemoteSpaceTemp K2 is bound to a LONWORKS space sensor, the Lan Remote Temp Select bit 58.7 is set true and logic module G10 causes S1 to be the RemoteSpaceTemp K2. This will also happen if Local Space Temp has a Read or Out of Limits error. Thus RemoteSpaceTemp K2 can either be a sensor fail default, or it can be a value bound to a LONMARK sensor.

**Deadbands/Heating & Cooling Setpoints (Diagram 3, strategy page 5)**

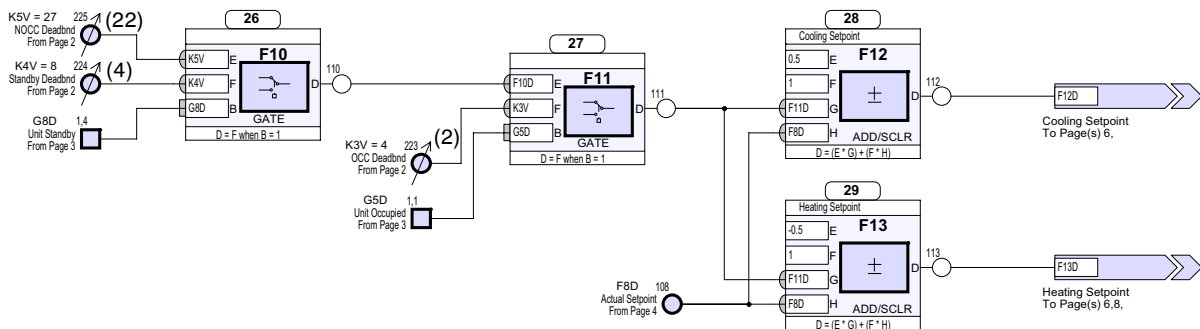

changes for the /USA/UL/ strategy shown in brackets

**Summary:**

The current deadband is selected from the NOCC deadband (default /UK/: 27 °C, /USA/UL/: 22 °F), Standby Deadband (default /UK/: 8 °C, /USA/UL/: 4 °F), OCC Deadband (default /UK/: 4 °C, /USA/UL/: 2 °F) according to the unit's occupancy state.

The Heating Setpoint is the **Setpoint** minus half the current deadband, and the Cooling Setpoint is the **Setpoint** plus half the current deadband.

$$\text{Heating Setpoint} = \text{Setpoint} - \frac{1}{2}(\text{deadband})$$

$$\text{Cooling Setpoint} = \text{Setpoint} + \frac{1}{2}(\text{deadband})$$

**Details:**

The function modules F10 and F11 produce a deadband according to the unit state; if Unit Occupied is true, the OCC Deadband K3 (default /UK/: 4 °C, /USA/UL/: 2 °F) is selected, if Unit in Standby is true, the Standby Deadband K4 (default /UK/: 8 °C, /USA/UL/: 4 °F) is selected, and if otherwise i.e. non-occupied, the NOCC Deadband K5 is selected (default /UK/: 27 °C, /USA/UL/: 22 °F). The function modules F12 and F13 add and subtract half the deadband from the Actual Setpoint to produce the Heating (F12) and Cooling (F13) loops' Setpoints respectively.

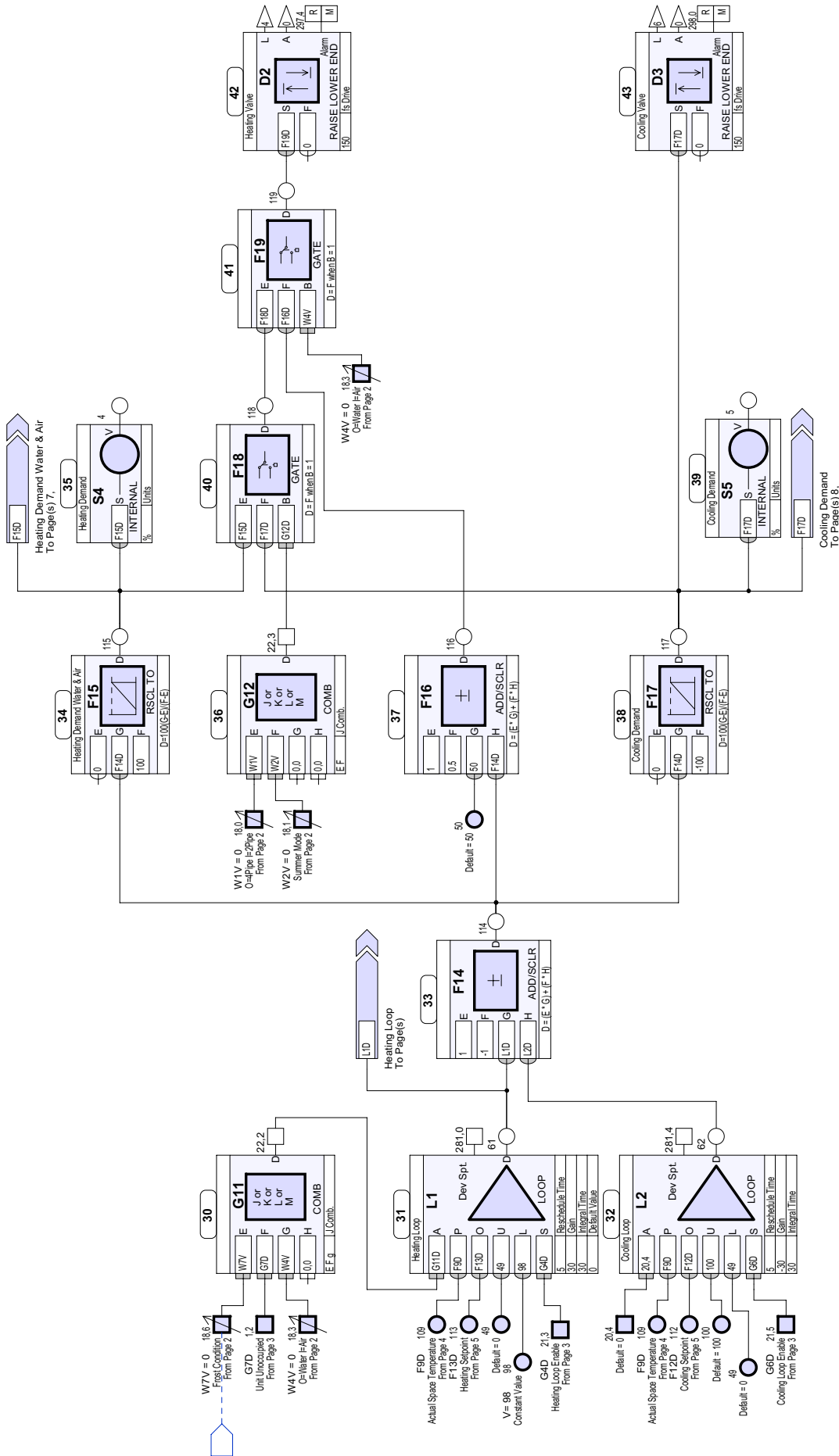

Heat/Cool Control (Diagram 4, strategy page 6)

Heat/Cool Control (Diagram 4, strategy page 6)

Summary:

Heating and Cooling Loops

The heating and cooling sides are controlled by different control loops.

The Heating Loop is enabled for a 2 pipe strategy in Winter Mode, or for a 4 pipe strategy all the time. The Cooling Loop is enabled if the fan is running for a 2 pipe strategy in Summer Mode, or for a 4 pipe strategy all the time. If the Heating Loop is disabled, its setpoint is set to zero. If the Cooling Loop is disabled, the output is effectively set to zero. The **Remote Shutdown** or enabled **Window Contact** disables the both loops.

The Heating Loop compares the **Space Temp** with the heating setpoint. The proportional + integral (P+I) loop will modulate the heating output to maintain a constant space temperature. As the temperature decreases below the heating setpoint the heating output will modulate open. The heating output will be modulated closed as the temperature increases above the heating setpoint. When the unoccupied mode is entered the heating loop's setpoint is decreased by the deadband mechanism explained above. The loop output is limited to the range 0 to 100%.

The Cooling Loop compares the **Space Temp** with the cooling setpoint. The proportional + integral (P+I) loop will modulate the cooling output to maintain a constant space temperature. As the temperature increases above the cooling setpoint the cooling output will modulated open. The cooling output will be modulated closed as the temperature decreases below the cooling setpoint. When the unoccupied mode is entered the cooling loop is disabled and its output is set to zero. The loop output is limited to the range 0 to 100%.

Error, E = setpoint - **Space Temp**

$$LoopOutput = G(E) + \int \frac{G(E)}{I} .dt$$

Where G = Loop gain

I = Integral time constant

The integral time constant is the time for which the loop output will have added to it an amount equal to product of the error and the gain (i.e. equal to the proportional part) under conditions of constant error. So if the error stays the same for the integral time constant, the loop output will double and will be 2G(E).

The loops have the following default settings :heat loop gain = 30, cool loop gain = -30, both loop integral time constants = 30 mins. These settings can be changed by text comms.

The output from the loops (ignoring the integral action) is illustrated by the chart below:

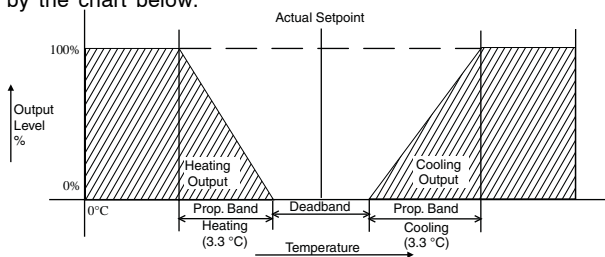

The heating loop will not operate until the **Space Temp** drops below the **Setpoint** by half the deadband (e.g. default = /UK/: 22-2=20, /USA/UL/: 72-1=71 during occupation). Similarly for cooling it must rise above by half the deadband. The loop gains are set to ±30 by default which gives proportional bands of (100/30=/UK/: 3.3 °C, /USA/UL/: 3.3 °F). When set to defaults, during occupation, this will give 100% heat at /UK/: 16.7 °C, /USA/UL/: 67.7 °F and 100% cool at /UK/: 27.3 °C, /USA/UL/: 76.3 °F (ignoring the effect of the integral term).

The heating loop is overridden to 98% if the **Frost Condition** is set during non-occupation) and the unit is running a water side strategy. This will bring on maximum heating without the supplementary electric heater.

The loop outputs are added together and then split into separate heating and cooling outputs to prevent simultaneous heating and cooling. The combined and separate heat and cool outputs are selected to drive the 4 output channels (4, 5, 6, 7) as required by the strategy type by the switches **O=4Pipe I=2Pipe (W1)**, **O=Water I=Air (W4)**, and **Summer Mode (W2)**. The driver type is also changed according to the strategy.

For the airside strategy (/AR2) the combined heating and cooling output drives the heat/cool damper.

For a 4 pipe strategy (/WR4, WT4) the heating output drives the heating valve and the cooling output drives the cooling valve. For a 2 pipe strategy (/WR2, WT2), the heat or cool valve demand comes from the heating loop in the winter, and the cooling loop in the summer as set by the Summer Mode setting.

Detail:

When the loops are disabled by means of the setpoint selection, S, inputs, the heating and cooling, U, setpoints are set to 0 and 100 respectively. This ensures that the heating loop output will not rise unless the temperature drops below /UK/: 0 °C, /USA/UL/: 0 °F and the cooling loop will not rise (as the temperature is not likely to exceed /UK/: 100 °C, /USA/UL/: 100 °F).

If the Frost Condition is set (W7=I), and the unit is Unoccupied with a Water side strategy (W4=O), the output of G11 forces the heating loop into manual by way of its A input which cause the output to equal its L input, i.e. 98% heating.

The heating and cooling loop outputs are added by F14 to give -100 to +100 maximum cool to maximum heat. They are then rescaled by modules F15 and F17 so that F14 output of 0 to +100 gives Heating Demand (S4), 0 to 100%, and F14 output of -100 to 0 gives Cooling Demand (S5), 100 to 0%. Combining the loop outputs in this way prevents simultaneous heating and cooling. The Cooling Demand drives the cooling output by way of driver D3. The Heating Demand is connected directly to the heating output by way of F18, F19, and driver D2 if the strategy is 4 pipe (W1=O) and Water side (W4=O) i.e /WR4 or /WT4.

If the strategy is 2 pipe (W1=I) and Summer Mode switch is set to Summer (W2=I), the output of G12 will cause F18 to gate the cooling demand through to the 'heating' output, i.e for /WR2 or /WT2.

The combined output of -100 to +100 from F14 is scaled by F16 to 0 to 100 (maximum cool to maximum heat) i.e. 50% is no heating or cooling. This is switched through to the heating output if the strategy is Airside (W4=I) i.e. for /AR2 strategy.

The D2 and D3 driver types, their function, and the output channels used, vary with the strategy type as shown in the table below. The strategy may be changed using text comms as detailed in the Changing the Strategy section.

| Strategy | D2                             |               |                    | D3                             |               |            |
|----------|--------------------------------|---------------|--------------------|--------------------------------|---------------|------------|
|          | Type                           | Channels used | Function           | Type                           | Channels used | Function   |
| AR2      | 4 Raise/Lower (floating point) | 4, 5          | Heat/cool damper   | 0                              | not used      | not used   |
| WR2      | 4 Raise/Lower (floating point) | 4, 5          | Heat or cool valve | 0                              | not used      | not used   |
| WR4      | 4 Raise/Lower (floating point) | 4, 5          | Heat valve         | 4 Raise/Lower (floating point) | 6, 7          | Cool Valve |
| WT2      | 3 Time Proportional            | 4             | Heat or cool valve | 0                              | not used      | not used   |
| WT4      | 3 Time Proportional            | 4             | Heat valve         | 3 Time Proportional            | 6             | Cool valve |

Note that for a raise/lower driver (e.g D2, D3 in AR2, WR2, WR4) the full scale drive time should not be greater than 262s.

Note that after a reset (power or programmed) and at midnight each Raise/Lower (floating point) driver will recalibrate the valve or damper position by driving the valve or damper to the calculated zero position (fully closed) and then overdrive for one complete driver period, (full scale drive time) to ensure the valve or damper is fully closed. It will then drive the valve or damper to the position required by the calculated demand.

Electric Heater Control (Diagram 5, strategy page 7, /E only)

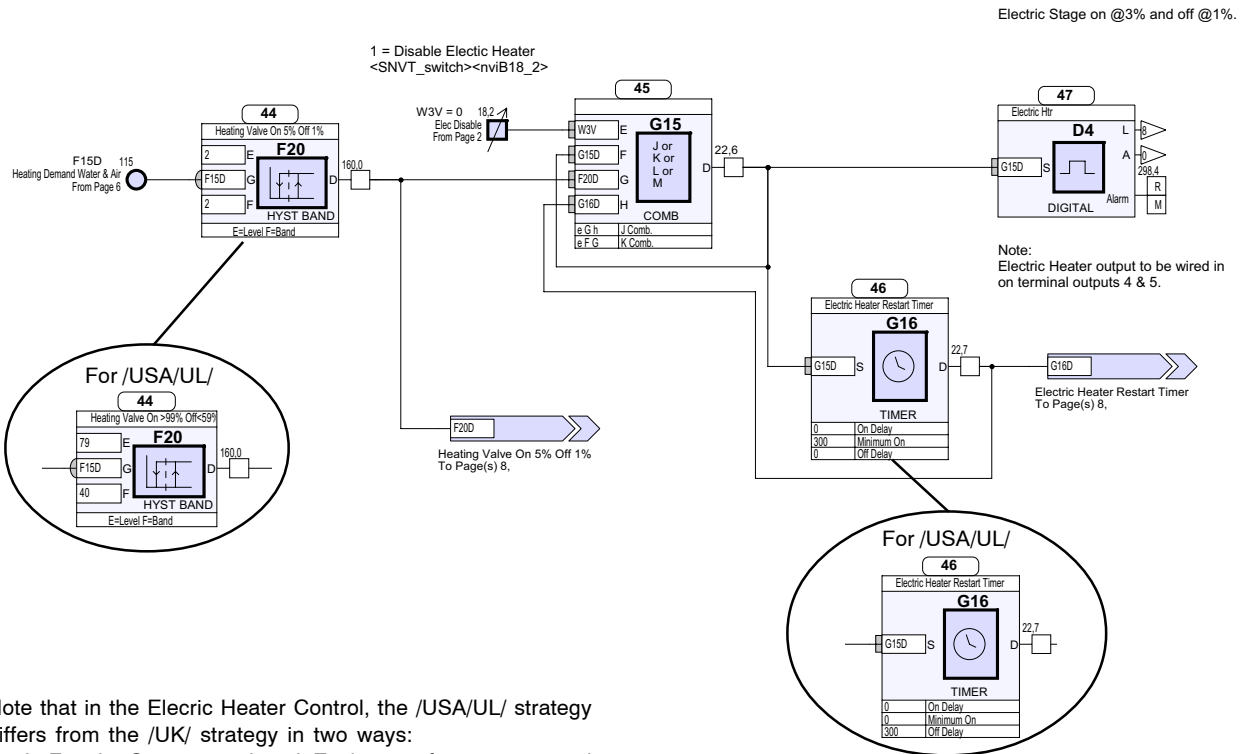

Note that in the Electric Heater Control, the /USA/UL/ strategy differs from the /UK/ strategy in two ways:

In F20 the Comparator Level, E, changes from 2 to 79, and the Hysteresis Band, F, changes from 2 to 40.

In G16 the timer logic module changes from a Minimum On timer to an Off Delay timer.

The **Electric Htr** output will be switched on as the heating demand rises above (/UK/: 3%, /USA/UL/: 99%) and be switched off as the heating demand drops below (/UK/: 1%, /USA/UL/: 59%). There is a 5 minute delay (default) after the switch on before the heater can be switched on again. The **Disable Electric Heater** switch will disable the output when set true.

**Detail:**

The hysteresis band function module F20 calls for electric heat if the Heating Demand is greater than (/UK/: 3%, /USA/UL/: 99%) and will call for it to be switched off if it falls below (/UK/: 1%, /USA/UL/: 59%). G15 will disable the output if the Disable Electric Heater W3 is set true. G15 will drive the electric heat on by way of digital driver D4. This will also start the timer G16 whose output will disable the original condition within G15 (eGh) but G15's output will be held high by the feedback of its output by way of G15's second condition (eFG). When input G to G15 falls, the electric heat will be switched off.

In the /UK/ strategy G16 will stop it restarting for at least its minimum on time (default =300 secs, 5 mins). In the /USA/UL/ strategy the off delay in G16 will prevent the heater being switched on again for the off delay period (default=300 secs, 5 mins).

## Auxiliary Relay Control (Diagram 6, strategy page 7, /AUX only)

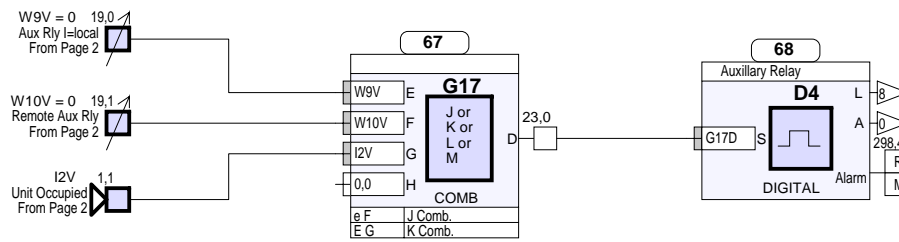
**Summary**

The Aux Rly I=local switch is set to O by default which causes the Auxiliary Relay to be driven by the Remote Aux Rly switch (switch on/relay energised). If Aux Rly I=local is set to I then the Auxiliary Relay is driven by the Unit Occupied Status (unit occupied/relay energised).

**Detail:**

Switch W3, (Aux Rly I=local) is used to select local or remote control of the relay. If W3=O then W9 (Remote Aux Rly) has control of the relay, whereas if W3=I, the Unit Occupied status has control of the relay. Both W3 and W9 are set to zero by default, so the relay is off. The logic module G16 drives the auxiliary relay by way of digital driver D4 if W3=I and Unit is Occupied, or W3=O and W9=I, otherwise the relay is off.

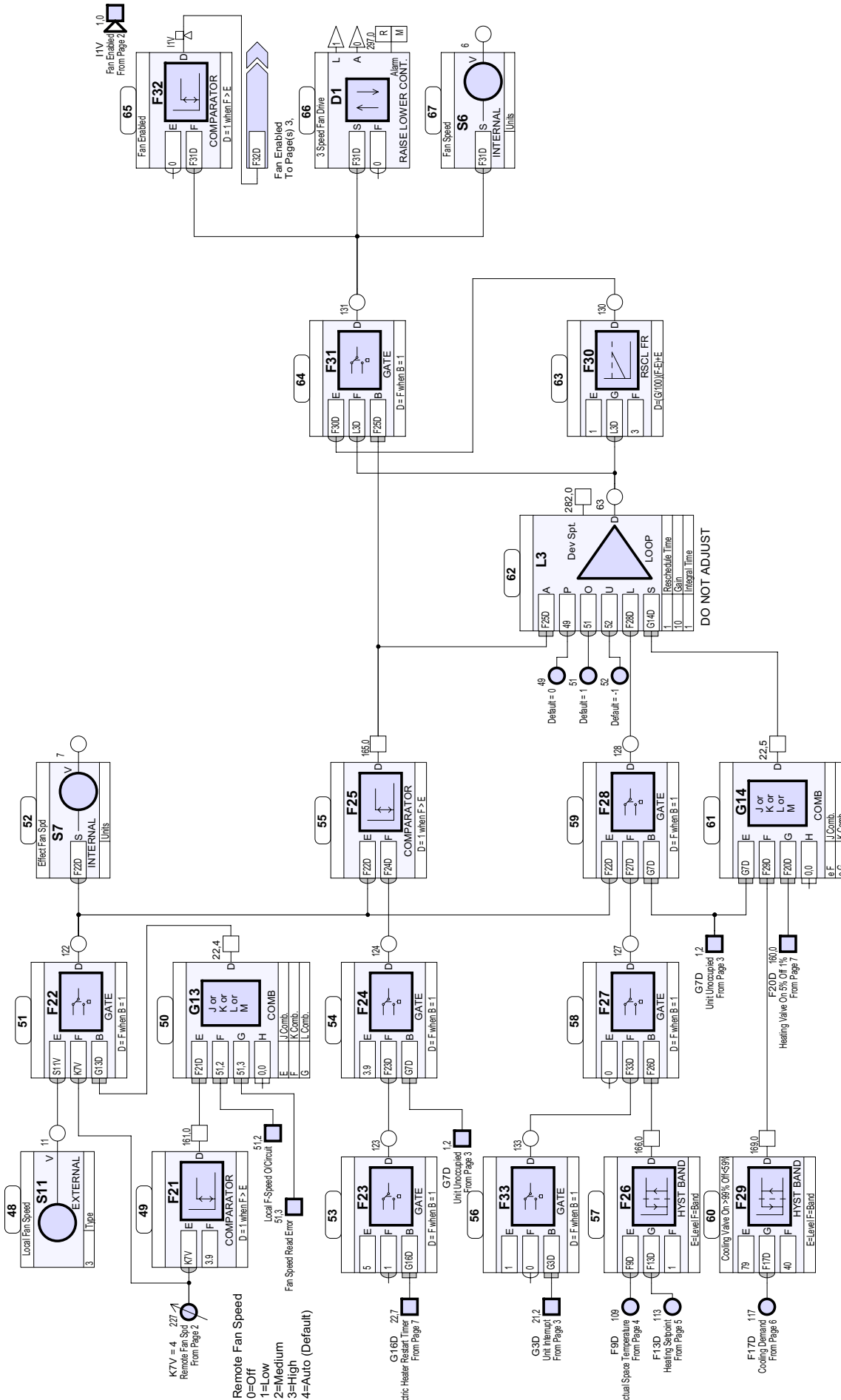

Fan Speed Control (Diagram 7, strategy page 8)

## Fan Speed Control (Diagram 7, strategy page 8)

### Summary:

While occupation state is **Unit Occupied** or **Unit in Standby** the **Effective Fan Spd** is selected by **Remote Fan Spd**. If the Remote Fan Spd is set to Auto, the **Local Fan Spd** takes control. However, if the Local Fan Spd input has an open circuit or read error, control will return to Remote Fan Spd. With the Effective Fan Spd set to Off, Low, Medium, or High, the fan control outputs will be driven appropriately. If the Effective Fan Spd is Auto, the fan will normally be running at low speed, but as the heating or cooling demand increases the fan speed will be increased to meet demand, similarly the fan speed will be reduced as demand is met.

This is achieved by using the integral function of a control loop. By default it has an error of 1, a gain of 10, and an integral time of 1 minute. The loop output is rescaled so that 0% corresponds to low speed, 50% to medium, and 100% to high speed. Thus the change from low to medium and from medium to high is 50%. The output will start at 10% and wind up to 50 % in 4 mins. It will then take a further 5 mins to reach 100%. The loop gain and integral may be changed to adjust the delay between fan speed changes.

While occupation state is **Unit Unoccupied** the fan is normally switched off. It comes on for building fabric protection if the temperature falls below the heating setpoint by 0.5 (default=/UK/: 22-13.5-0.5=8 °C, /USA/UL/: 72-11-0.5=60.5 °F). The fan will be switched off as the temperature rises above the heating setpoint by 0.5 (default=/UK/: 9 °C, /USA/UL/: 61.5 °F). The **Window Contact** or **Remote Shutdown** will override fabric protection off.

The fan is also brought on during non-occupation if the electric heater is running or during its cool down delay period, as long as the Effective Fan Speed is not zero (i.e. not Off).

### Detail:

F21 checks that the Remote Fan Spd (K7) is not Auto (4). The output of G13 is true for this non auto condition or if the Local Fan Speed input has an open circuit or read error. The output of G13 switches F22 to use the Remote Fan Spd as the Effective Fan Spd (S7). If the Remote Fan Spd is Auto and the Local Fan Spd is OK then Local Fan Spd is connected to the Effective Fan Spd.

The Effective Fan Spd is compared with the F24 output by F25. During Occupation the F24 output is 3.9 so the output of F25 is true unless Effective Fan Spd is Auto (4). For non-auto Effective Fan Spd (off, low medium or high), F25 drives the loop L3 into manual. During occupation F28 connects the Effective Fan Spd to the loop manual level so the loop output is 0, 1, 2, or 3. The output of F25 switches F31 to connect the loop output to the fan driver D1. This is monitored by Fan Speed sensor (S6), and produces the Fan Enabled status (I1). The heating loop is enabled by the fan during occupation and also during non-occupation regardless of the fan (see diagram 1). Also in diagram1 the cooling loop is enabled by the fan at any time but the fan is only on during occupation and for heating during non-occupaton so effectively the cooling is only on during occupation.

During Occupation if the Effective Fan Speed is Auto (4), the F25 output is zero, so the loop goes to auto. The loop's S input (setpoint select) is normally zero so the unoccupied setpoint (U) is used. This gives an error of zero (U<P) and the loop output is thus zero. This is rescaled by F30 to produce the value 1 (low speed). The F25 output of zero switches F31 to connect the output of F30 to the fan driver. So in Auto during occupation the fan speed is normally low. As Cooling demand rises above 99% F29 output goes true. It will fall back to zero as the cooling demand falls below 59 %. This same function for the heating demand was generated in the electric heater section by the output of F20. During occupation G14 will switch the loop to use the occupied setpoint for either cooling or heating demand above 99%. The loop now has an error of 1 (P-O=1) which will cause the loop output to be 10%. As the loop output winds up it will go through the 50% level which is rescaled by F30 to produce 2, medium fan speed, and with a loop output of 100% the F30 output will become 3, high fan speed.

During non-occupation F24 gates the normal output of F23 to the F25 comparator. This value of 5 is always greater than the value of Effective Fan Spd so F25 output is one, the loop is set to manual and F28 gates the output of F27 (normally 0) through to the loop manual level. This sets the loop output to zero (fan off) and the F25 output of one causes F31 to switch through the loop fan off output to the fan driver.

Fabric protection during non-occupation is provided by F26. If the actual Space Temperature falls below the Heating Setpoint by 0.5 (/UK/: 0.5 °C, /USA/UL/: 0.5 °F), F26 output goes true and causes F27 to gate the output of F33 (normally 1) to F28 which will set the loop manual level to 1 (low fan speed). This is connected to the fan driver as described above, and will enable the heating by way of the Fan enabled state.

As the Actual Space Temperature rises above the heating setpoint by 0.5 (/UK/: 0.5 °C, /USA/UL/: 0.5 °F) the output of F26 will go to zero and switch the fan back off. If the Window contact or Remote Shutdown operate, the Unit interrupt will cause the F33 output to be zero and will switch off the fabric protection strategy.

During non-occupation if the Electric Heater is on or during its cooldown phase the timer G16 output will be true (see diagram 5) and will switch the output of F23 to one. This will cause the output of F24 to be one which will which will drop the F25 output to off unless the Effective Fan Speed is zero (fan Off). With F25 output being off, the F30 output will be connected through to the fan driver by way of F31, and since its minimum value is 1, the fan must come on.

## Changing the Strategy

The IQL strategy can be changed using the Switches, **O=4Pipe I=2Pipe** (W1), and **O=Water I=Air** (W4), and the drivers D2 and D3. These changes are made easily using the 'Strategy Type' feature in IqlTool 2. If not using IqlTool2, the changes can be made using a suitable IQ system tool and the terse text communications strings shown below:

/AR2

D2(\$="Damper",Y=4),D3(\$="Dummy",Y=4),W1(S=O),W4(S=I),R(z=1)

wait 10 s

D2(D=150),D3(D=150),R(z=1)

*Note that although AR2 implies 2 pipe, both heat and cool outputs need to be enabled for the airside strategy, hence W1=O, 4 pipe.*

/WR2

D2(\$="Heat Cool Valve",Y=4),D3(\$="Dummy",Y=4),W1(S=I),W4(S=O),R(z=1)

wait 10 s

D2(D=150),D3(D=150),R(z=1)

/WR4

D2(\$="Heating Valve",Y=4),D3(\$="Cooling Valve",Y=4),W1(S=O),W4(S=O),R(z=1)

wait 10 s

D2(D=150),D3(D=150),R(z=1)

/WT2

D2(\$="Heat Cool Valve",Y=3),D3(\$="Dummy",Y=3),W1(S=I),W4(S=O),R(z=1)

wait 10 s

D2(P=100),D3(P=100),R(z=1)

/WT4

D2(\$="Heating Valve",Y=3),D3(\$="Cooling Valve",Y=3),W1(S=O),W4(S=O),R(z=1)

wait 10 s

D2(P=100),D3(P=100),R(z=1)

Reversion to strategy version 12 (/UK/ only).

The /UK/ strategy version 13 has settings modified for e.bac certification; these can be changed back to version 12 settings, but this will cancel eu.bac certification. Note that eu.bac certification only applies to /UK/, /WR2/ and /WR4/ strategies.

To change the IQL to pre eu.bac settings (i.e. strategy version 12) change the following parameters:

K1(V=20),K3(V=1,T=2),K4(V=2,T=3),K5(V=12,T=20),L1(G=40,I=0),L2(G=-40,I=0),G16(F=300, M=0)

(for /AR2, /WR2, /WR4 only) D2(D=180),D3(D=180)

Note that it is not possible to change back the Electric Heater Control to operate as strategy version 12. In strategy version 13 the heater comes on as heating demand increases above 3 %, whereas in version 12 it comes on as it increases above 99%.

## Using RD-IQL

The parameters changed by the RD-IQL are:

**S9, Local Space Temp** (RD-IQL/K, /KOS, /KOSF)

**S10, Local SP Adjust** (RD-IQL/K, /KOS, /KOSF)

**I9, Pushbutton PIR** (RD-IQL/KOS, /KOSF)

**S11, Local Fan Speed** (RD-IQL/KOSF)

The parameters displayed on the RD-IQL are:

**S1, Space Temp** (RD-IQL/K, /KOS, /KOSF)

**S2, Actual Setpoint** (RD-IQL/K, /KOS, /KOSF)

**S3, Occupancy** (RD-IQL/KOS, /KOSF)

**S7, Effect Fan Spd** (RD-IQL/KOSF)

The IQL must be set up to use the RD. The changes are made easily using the 'Configure for RD-IQL' feature in IqlTool 2. If not using IqlTool2, the changes can be made using a suitable IQ system tool and the terse text communications strings shown below:

Local Space Temp Type, **S9(Y=6)** (use RD)

Local SP Adjust Type, **S10(Y=6)** (use RD)

Local Fan Speed Type, **S11(Y=6)** (use RD)

O=Pb I=PIR, **W6(S=O)** (Pushbutton selected, default)

Remote Fan Spd, **K7(V=4)** (auto, default)

This should be terminated by a text comms reset command R(z=1) to write changes to flash and reset the unit. (Note that this command clears logged date and sets time to zero.)

It is possible to use the RD in conjunction with a separate temperature sensor connected to IN1. To do this, leave Local Space Temp Type as default, S9(Y=1). It is recommended to configure the RD to 'Use local thermistor' so that it displays the correct temperature value.

It is possible to use the RD in conjunction with a separate fan speed select switch connected to IN3. To do this, leave Local Fan Speed Type as default, S11(Y=3).

## INSTALLATION

The IQL15+/xxx installation is covered by the IQL15+/xxx Installation Instructions TG200344.

## ORDER CODES

|                                  |   |
|----------------------------------|---|
| <b>IQL15+/AR2/E/24VAC</b>        | IQL15+ with Airside, Raise/Lower (floating point) Strategy, electric heater output and 24 Vac supply                                    |
| <b>IQL15+/AR2/E/230</b>          | IQL15+ with Airside, Raise/Lower (floating point) Strategy, electric heater output and 230 Vac supply                                   |
| <b>IQL15+/WR2/E/24VAC</b>        | IQL15+ with Water Side, 2 Pipe, Raise/Lower (floating point) Strategy, electric heater output and 24 Vac supply                         |
| <b>IQL15+/WR2/E/230</b>          | IQL15+ with Water Side, 2 Pipe, Raise/Lower (floating point) Strategy, electric heater output and 230 Vac supply                        |
| <b>IQL15+/WR4/E/24VAC</b>        | IQL15+ with Water Side, 4 Pipe, Raise/Lower (floating point) Strategy, electric heater output and 24 Vac supply                         |
| <b>IQL15+/WR4/E/230</b>          | IQL15+ with Water Side, 4 Pipe, Raise/Lower (floating point) Strategy, electric heater output and 230 Vac supply                        |
| <b>IQL15+/WT2/E/24VAC</b>        | IQL15+ with Water Side, 2 Pipe, Thermic Strategy, electric heater output and 24 Vac supply  |
| <b>IQL15+/WT2/E/230</b>          | IQL15+ with Water Side, 2 Pipe, Thermic Strategy, electric heater output and 230 Vac supply   |
| <b>IQL15+/WT4/E/24VAC</b>        | IQL15+ with Water Side, 4 Pipe, Thermic Strategy, electric heater output and 24 Vac supply  |
| <b>IQL15+/WT4/E/230</b>          | IQL15+ with Water Side, 4 Pipe, Thermic Strategy, electric heater output and 230 Vac supply   |
| <b>IQL15+/AR2/AUX/24VAC</b>      | IQL15+ with Airside, Raise/Lower (floating point) Strategy, Auxiliary Relay output and 24 Vac supply                                    |
| <b>IQL15+/AR2/AUX/230</b>        | IQL15+ with Airside, Raise/Lower (floating point) Strategy, Auxiliary Relay output and 230 Vac supply                                   |
| <b>IQL15+/WR2/AUX/24VAC</b>      | IQL15+ with Water Side, 2 Pipe, Raise/Lower (floating point) Strategy, Auxiliary Relay output and 24 Vac supply                         |
| <b>IQL15+/WR2/AUX/230</b>        | IQL15+ with Water Side, 2 Pipe, Raise/Lower (floating point) Strategy, Auxiliary Relay output and 230 Vac supply                        |
| <b>IQL15+/WR4/AUX/24VAC</b>      | IQL15+ with Water Side, 4 Pipe, Raise/Lower (floating point) Strategy, Auxiliary Relay output and 24 Vac supply                         |
| <b>IQL15+/WR4/AUX/230</b>        | IQL15+ with Water Side, 4 Pipe, Raise/Lower (floating point) Strategy, Auxiliary Relay output and 230 Vac supply                        |
| <b>IQL15+/WT2/AUX/24VAC</b>      | IQL15+ with Water Side, 2 Pipe, Thermic Strategy, Auxiliary Relay output and 24 Vac supply  |
| <b>IQL15+/WT2/AUX/230</b>        | IQL15+ with Water Side, 2 Pipe, Thermic Strategy, Auxiliary Relay output and 230 Vac supply   |
| <b>IQL15+/WT4/AUX/24VAC</b>      | IQL15+ with Water Side, 4 Pipe, Thermic Strategy, Auxiliary Relay output and 24 Vac supply  |
| <b>IQL15+/WT4/AUX/230</b>        | IQL15+ with Water Side, 4 Pipe, Thermic Strategy, Auxiliary Relay output and 230 Vac supply   |
| <b>IQL15+/AR2/E/USA/UL/24VAC</b> | IQL15+ with Airside, Raise/Lower (floating point) Strategy, electric heater output and 24 Vac supply. USA version. UL rated.            |
| <b>IQL15+/WR2/E/USA/UL/24VAC</b> | IQL15+ with Water Side, 2 Pipe, Raise/Lower (floating point) Strategy, electric heater output and 24 Vac supply. USA version. UL rated. |
| <b>IQL15+/WR4/E/USA/UL/24VAC</b> | IQL15+ with Water Side, 4 Pipe, Raise/Lower (floating point) Strategy, electric heater output and 24 Vac supply. USA version. UL rated. |

## SPECIFICATIONS

### Electrical

|        |   |
|--------|---|
| Supply |   |
| /230   | :230 Vac -10% +15%, 50/60 Hz  |
| /24VAC | :24 Vac ±15%, 50/60 Hz  |
| Power  |   |
| /230   | :Up to 13 VA which consists of 3 VA internal power plus power to triac outputs  |
| /24VAC | :Up to 12.1 VA which consists of 2.5 VA internal power plus power to triac outputs.<br>In both cases the maximum shared between all triac outputs used is 400 mA.   |
| Inputs |   |
| IN1    | :Thermistor input (S9). Scaled for standard IQ system thermistor (10 kΩ at 25 °C, 77 °F). Scaling range 2.5 °C to 60 °C (36.5 °F to 116 °F). Conversion accuracy ±0.25 °C (±0.45 °F) over range (10 °C to 30 °C, 50 °F to 86 °F).   |
| IN2    | :Potentiometer Input (S10). Potentiometer input range (1 to 11 kΩ) has 0.1% resolution. Self calibrating 0 to 100 % over range used. Gives trim 0 to 1, which is added to sensor offset (default - ½) to give range (default - ½ to +½); this is multiplied by Offset Range (K15, default /UK/ 2°C, /USA/UL/ 2 °F) to produce trim on setpoint (default /UK/ -1°C to +1 °C, /USA/UL/ -1 °F to +1 °F).   |
| IN3    | :Fan Speed Select Input (S11). Resistance input range (0 to 12 kΩ) has 0.1% resolution. Input resistance set to 1 of five values (4k7, 8k0, 11k3, 14k6, 17k9Ω) which correspond to 0-Off, 1-Low, 2-Medium, 3-High, and 4-Auto.  |
| IN4    | :Pushbutton or Passive Infra Red movement detector contact Input (I9). (Volt free contact input. 5 Vdc supply through 10 kΩ. Wetting current 0.5 mA.)<br>Input is either a pushbutton, or Passive Infra Red (PIR) movement detector. It will bring the fan and heat/cool outputs into operation when the contact is closed for at least 1 second (dependent on unit state)<br>Input can be used for connection of RD-IQL with following options:<br>RD-IQL/K provides thermistor temperature sensor and setpoint trim<br>RD-IQL/KOS provides the same as RD-IQL/K plus occupation override pushbutton and occupation status display.<br>RD-IQL/KOSF provides the same as RD-IQL/KOS plus fan speed select and display |
| IN5    | :Alarm (e.g. filter blocked) or Window Contact Input (I10). With Window Mode (W5) set to 1, it will switch off fan and close valves when contact is open (window is open). (Volt free contact input. 5 Vdc supply through 10 kΩ. Wetting current 0.5 mA.)   |

### Outputs

|                         |   |
|-------------------------|---|
| OUT1/OUT2/OUT3          | :Fan Speed Relay Outputs. Changeover relay contacts. Output rated at 5 A maximum at 240 Vac ( $\cos\phi \geq 0.4$ ) and 30 Vdc (resistive load). Reduce to 2 A for 24 Vdc (inductive load, $T \leq 30$ ms). For /USA/UL/24VAC, UL rating applies up to 30 V. Arc suppression circuit (RC) should be fitted for inductive loads, see TG200208. Fan speed control outputs select low, medium and high speed respectively. Outputs 1, 2, and 3 select fan speeds Low, Medium, or High respectively; all relays de-energised selects fan off. |
| OUT4, 5, 6, 7           | :Triac outputs equivalent to 24 Vac solid state relays. Total of 400 mA supply available to all four triac outputs. The function of these outputs varies with the strategy running in the controller:   |
| /AR2                    | OUT4/OUT5:Raise/Lower (floating point) outputs to heat/cool damper<br>OUT6/OUT7:unused triac outputs.   |
| /WR2                    | OUT4/OUT5:Raise/Lower (floating point) outputs to drive heating or cooling valve.<br>OUT6/OUT7:unused triac outputs   |
| /WR4                    | OUT4/OUT5:Raise/Lower (floating point) outputs to drive heating valve.<br>OUT6/OUT7:Raise/Lower (floating point) outputs to drive cooling valve.  |
| /WT2                    | OUT4 :Thermic output to drive heating or cooling valve.<br>OUT5/OUT6/OUT7 :unused triac outputs   |
| /WT4                    | OUT4 :Thermic output to drive heating valve.<br>OUT5 :unused triac output<br>OUT6 :Thermic output to drive cooling valve.<br>OUT7 :unused triac output  |
| OUT8                    | :(ER1) Normally open, make only, relay contacts. Output rated at 10 A maximum at 240 Vac ( $\cos\phi \geq 0.4$ ), and 28 Vdc (resistive load). Reduce to 2 A for 24 Vdc (inductive load, $T \leq 30$ ms). For /USA/UL/24VAC, UL rating applies up to 30 V. Arc suppression circuit (RC) should be fitted for inductive loads, see TG200208.<br>/E version: Electric Heater Output.<br>/AUX version: Auxiliary Relay Output.   |
| Version                 | :This document applies to the following version:  |
| Firmware                | :v5.1 or later  |
| Strategy                | :IQL15+ generic strategies: /UK/./E release 13, /UK/./AUX release 10, /USA/UL/ release US01   |
| Performance and Quality | :eu.bac certificate no. 020702. Compliant with eu.bac Specific Rules 2.1 in accordance with prEN15500. Applies to firmware version 5.1 or later with /UK/ generic strategy /E version 13, /AUX version 10, or greater, /WR2/ and /WR4/ only.  |

©Echelon, LON, Neuron, LONWORKS and LONMARK are trademarks of Echelon Corporation registered in the United States and other countries.

Please send any comments about this or any other Trend technical publication to [techpubs@trendcontrols.com](mailto:techpubs@trendcontrols.com)

©2008 Honeywell Technologies Sàrl, ECC Division. All rights reserved. Manufactured for and on behalf of the Environmental and Combustion Controls Division of Honeywell Technologies Sàrl, Ecublens, Route du Bois 3, Switzerland by its Authorized Representative, Trend Control Systems Limited.

Trend Control Systems Limited reserves the right to revise this publication from time to time and make changes to the content hereof without obligation to notify any person of such revisions or changes.

### Trend Control Systems Limited

P.O. Box 34, Horsham, West Sussex, RH12 2YF, UK. Tel:+44 (0)1403 211888 Fax:+44 (0)1403 241608 [www.trend-controls.com](http://www.trend-controls.com)

### Trend Control Systems USA

6670 185th Avenue NE, Redmond, Washington 98052, USA. Tel: (425)897-3900, Fax: (425)869-8445 [www.trend-controls.com](http://www.trend-controls.com)