

## IQL11+/xxx Standard Strategies

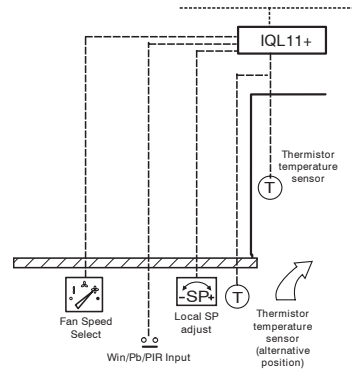

### IQL11+/... standard strategies inputs (common to all strategies)



### IQL11+/AR2 (Airside, Raise/Lower - Floating Point) outputs

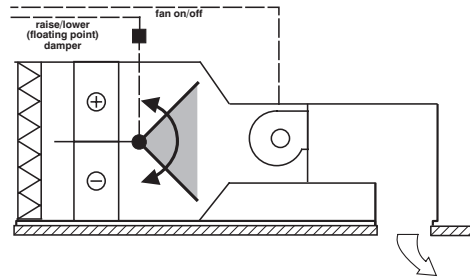

### IQL11+/WR2 (Water Side, Raise/Lower - Floating Point, 2 Pipe) outputs

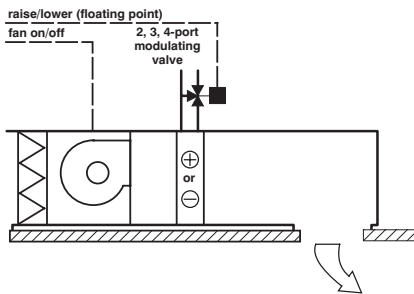

### IQL11+/WR4 (Water Side, Raise/Lower - Floating Point, 4 Pipe) outputs

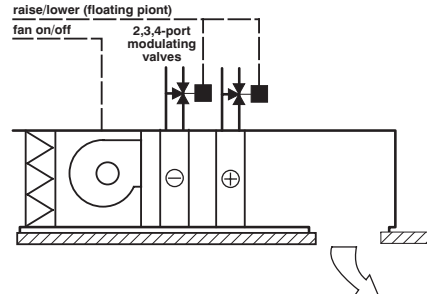

### IQL11+/WT2 (Water Side, Thermic, 2 Pipe) outputs

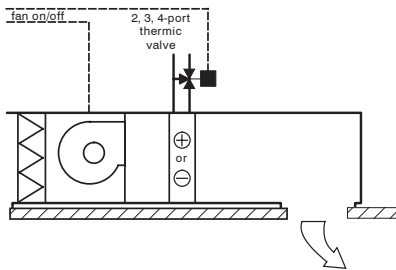

### IQL11+/WT4 (Water Side, Thermic, 4 Pipe) outputs

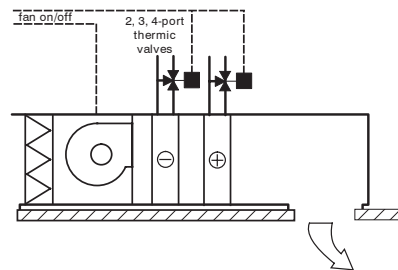

## Description

An IQL11+/xxx standard strategy controls a fan coil unit's heat/cool outputs, and on/off fan, in response to a thermistor temperature sensor with a local setpoint knob, and a local switch input (window contact, pushbutton, or Passive Infra Red movement detector input).

The heat/cool outputs vary with the strategy:

- /AR2 raise/lower (floating point) damper
- /WR2 raise/lower (floating point) heat or cool valve
- /WR4 raise/lower (floating point) heating and cooling valves
- /WT2 thermic heat or cool valve
- /WT4 thermic heating and cooling valves

## Features

- Fan on/off
- Range of heating and cooling outputs
- Local setpoint adjustment
- Window contact, pushbutton, or occupancy detector override
- Compatible with RD-IQL room display
- Conforms to LONMARK® profile 8501

CONNECTIONS

Inputs

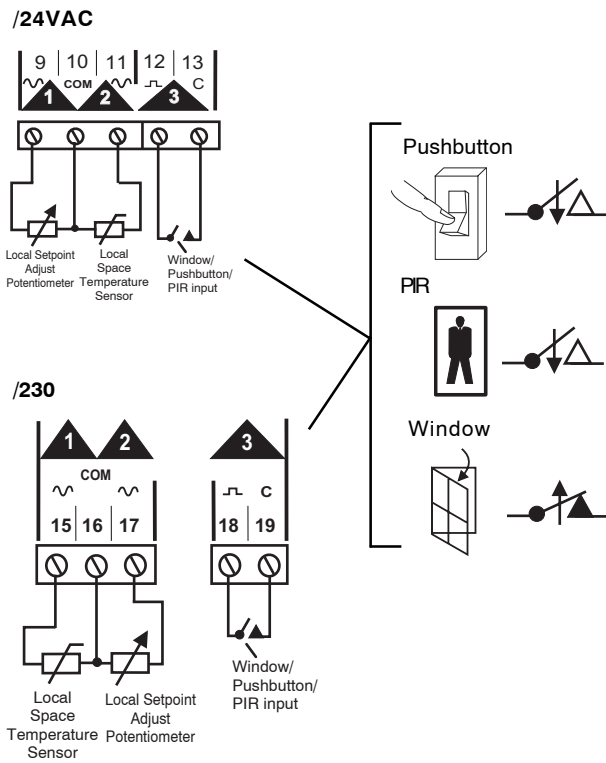

**Note use of IN1 and IN2 differs between /24VAC and /230 supply options**

All strategies have the same inputs. The inputs (except for the Window Contact or PIR) can be provided by the following products:

- TB/TS** space temperature sensor with options:
- TB/TS/K** TB/TS plus setpoint adjustment,
- TB/TS/KE** TB/TS/K plus occupation override pushbutton, *Note option /KEF is not applicable to IQL11+.*

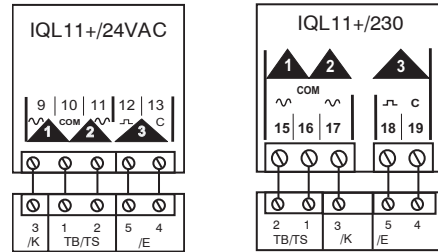

**RD-IQL**, room display connects via one input (IN3) and has options:

**RD-IQL/K**: includes space temperature sensor with setpoint adjustment. If a setpoint adjust is required the RD's potentiometer must be used (not IN2). A separate sensor connected to IN1 may be used instead of the RD's; this is achieved by maintaining the original sensor type for IN1. There will be no Window/PIR/Pushbutton input.

**RD-IQL/KOS**: RD-IQL/K plus occupation override pushbutton and occupation status display. It has the same limitations as RD-IQL/K but there is now a pushbutton input.

*Note option /KOSF is not applicable to IQL11+*

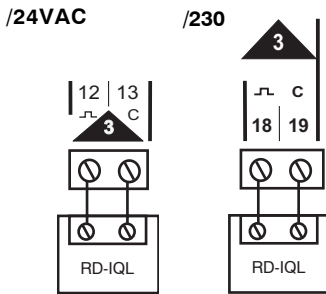

*Note that the IQL11+ must be configured using text communications to use the RD-IQL. The settings are listed in the 'Using RD-IQL' section, p15.*

Outputs

IQL11+/AR2 outputs

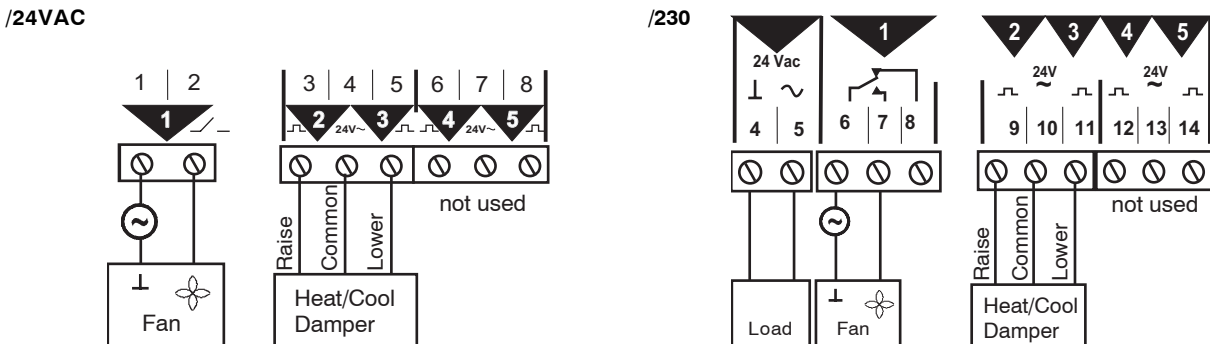

Outputs (continued)

IQL11+/WR2 outputs

/24VAC

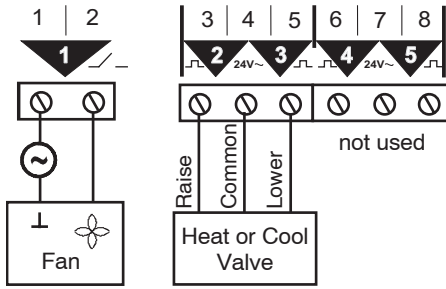

/230

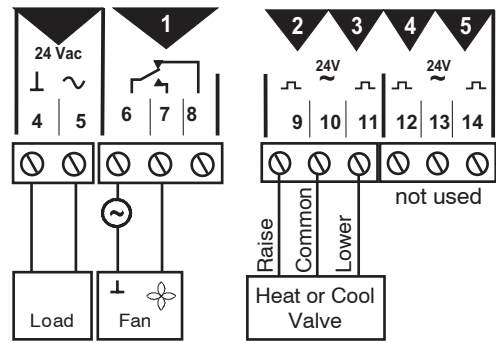

IQL11+/WR4 outputs

/24VAC

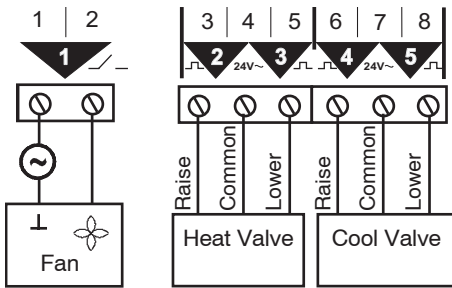

/230

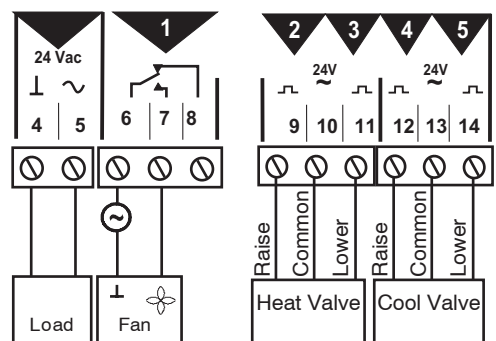

IQL11+/WT2 outputs

/24VAC

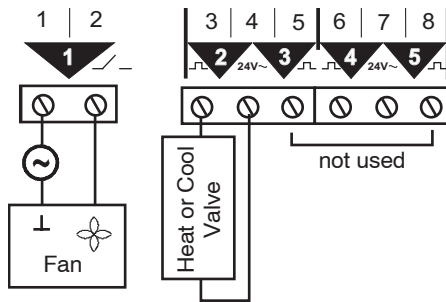

/230

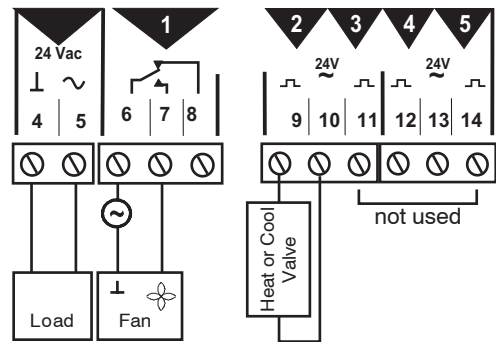

IQL11+/WT4 outputs

/24VAC

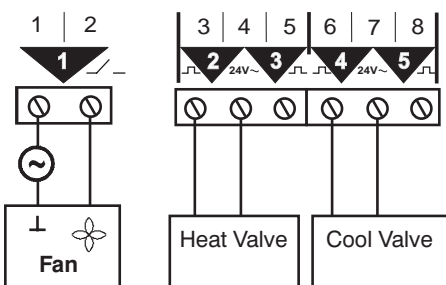

/230

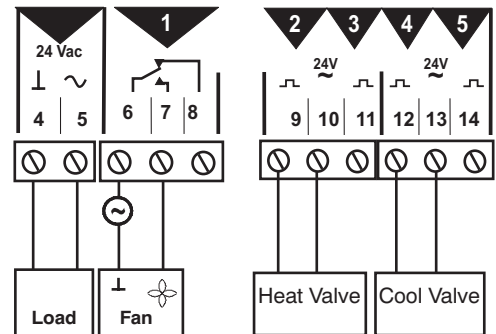

## FUNCTIONALITY

The IQL11+ functionality is described in the IQL11+ data sheet TA200113. This data sheet describes the additional functionality present when the controller is running a standard strategy.

### Real Inputs

The following real sensors and digital inputs are connected to the input channels and their values can be monitored by text comms (including IC Comms). The inputs IN1 to IN3 (except for window contact or PIR) can be provided by the RD-IQL/KOS Room Display connected to IN3:

#### Real Sensors

**S9** (/230, IN1; /24VAC, IN2): Local Space Temp, the thermistor temperature sensor reading.

**S10** (/230, IN2; /24VAC, IN1): Local SP Adjust, the local setpoint adjustment potentiometer value scaled in the range 0 to 1, and added to the default S10 offset of -1/2 to produce the range -1/2 to +1/2. This generates a setpoint trim in the range (/UK/: -1 °C to +1 °C, /USA/UL/: -1 °F to +1 °F) when the default Offset Range (K15) of (/UK/: 2 °C, /USA/UL/: 2 °F) is used.

#### Real Digital Inputs

**I9** (IN3): Window PB PIR, this input can be either a Window contact which opens (for at least 1 second), or a Pushbutton, or PIR (Passive Infra Red occupation detector) which closes (for a least 1 second) when the occupation override is required. The type of input is defined by W5 (Window Mode switch) and W6 (O=Pb I=PIR) as described below:

**Window Contact** (W5=I): The window contact opens as the window opens and changes the occupancy state to unoccupied and disables cooling, only allows sub-zero heating, and disables the fabric protection during non-occupation.

**PIR** (W5=O,W6=I): A contact closure (people present) effectively switches the unit from Standby into Bypass while people are present plus the Pb PIR Run On time (K13, default 30 mins). The Bypass state also produces the Unit Occupied state within the unit.

**Pushbutton** (W5=O,W6=O): A contact closure switches the state from any occupation state into Bypass for Pb PIR Run On time (K13, default 30 mins). The Bypass state also produces Unit Occupied state within the unit.

### Outputs

**Channel 1** (OUT1: /24VAC terminals 1, 2; /230 terminals 6, 7, 8): This relay output (/24 VAC: normally open make only contact; /230: changeover contact) is used to switch the fan on or off. The fan is normally off during non-occupation unless there is a heating demand for fabric protection or there is a demand for cooling. The fan is on during occupation (including bypass and standby states).

Item	Option	IN	Node	Description	Units	/UK/			/USA/UL/			Meaning	nv name	
						Default	Default range Bottom	Top	Units	Default	Default range Bottom			Top
Sensors														
Intern.	S1		A1	Space Temp	DegC	20			DegF	68				rvoSpaceTemp
	S2		A2	Setpoint	DegC	20			DegF	68				rvoEffectSetPt
	S3		A3	Occupancy	-	0			-	0			0(Occupied), 1(Unocc), 2(Bypass), 3(Standby)	rvoOccCmd
	S4		A4	Heating Demand	%				%					rvoHeatOutput
	S5		A5	Cooling Demand	%				%					rvoCoolOutput
Real														
S9	/24VAC	IN2	A9	Local SpaceTemp	DegC				DegF					thermistor
	/230	IN1	A9	Local SpaceTemp	DegC				DegF					thermistor
S10	/24VAC	IN1	A10	Local SP Adjust	Knob				Knob					-1/2 to +1/2 (potentiometer)
	/230	IN2	A10	Local SP Adjust	Knob				Knob					-1/2 to +1/2 (potentiometer)
Knobs														
K1			A17	Remote Setpoint	DegC	20	18	24	DegF	68	64	76		rviSetPoint
K2			A18	RemoteSpaceTemp	DegC	20	0	30	DegF	68	32	86		rviSpaceTemp
K3			A19	OCC Deadbnd	DegC	1	0.5	2	DegF	2	1	4		rviA19
K4			A20	Standby Deadbnd	DegC	2	1	3	DegF	4	2	4		rviA20
K5			A21	NOCC Deadbnd	DegC	12	8	20	DegF	22	15	36		rviA21
K6			A22	Remote Occ	-	0	0	3	-	0	0	3	0(Occupied), 1(Unocc), 2(Bypass), 3(Standby)	rviOccCmd
K8			A24	Remote SP Offset	DegC	0	-10	10	DegF	0	-10	10		rviSetPtOffset
K13			A29	Pb PIR Run On	Secs	1800	900	3000	Secs	1800	900	3000		
K15			A31	Offset Range	DegC	2	1	10	DegF	2	1	10		
Switches														
W1			B18,0	O=4Pipe I=2Pipe	*				*					rviB18_0
W2			B18,1	Summer Mode	O				O				O=Winter (heat only)	rviB18_1
W4			B18,3	O=Water I=Air	*				*					rviB18_3
W5			B18,4	Window Mode	O				O				I=Window mode	rviB18_4
W6			B18,5	O=Pb I=PIR	O				O				I=PIR	rviB18_5
W7			B18,6	Frost Condition	O				O				I=Frost Condition	rviB18_6
W8			B18,7	Remote Shutdown	O				O				I=Shutdown	rviB18_7
Digital Inputs														
Intern.	I1		B1,0	Fan Enabled										rvoB1_0
	I2		B1,1	Unit Occupied	I (Occ)				I (Occ)				(default from K6)	rvoB1_1
	I3		B1,2	Unit Unoccupied	O				O				(default from K6)	rvoB1_2
	I4		B1,3	Unit in Bypass	O				O				(default from K6)	rvoB1_3
	I5		B1,4	Unit in Standby	O				O				(default from K6)	rvoB1_4
Real	I9		IN3/B2,0	Window PB PIR									(contact closes =I)	

#### Strategy Items

**Channels 2, 3** (OUT2, 3: /24VAC terminals 3, 4, 5; /230 terminals 9, 10, 11): Two triac outputs.

**Channels 4, 5** (OUT4, 5: /24VAC terminals 6, 7, 8; /230 terminals 12, 13, 14): Two triac outputs.

Channels 2, 3 are used by driver module 2, and channels 4, 5 are used by driver module 3. The types of these driver modules are set according to the strategy requirements as shown in the table below. They can be changed after installation by text comms - see Changing the Strategy section.

Channel	OUT	Strategies				
		AR2	WR2	WR4	WT2	WT4
2	2	Raise heat/cool damper	Raise heat or cool valve	Raise heat valve	Drive heat or cool valve	Drive heat valve
3	3	Lower heat/cool damper	Lower heat or cool valve	Lower heat valve	not used	not used
4	4	not used	not used	Raise cool valve	not used	Drive cool valve
5	5	not used	not used	Lower cool valve	not used	not used

## FUNCTIONALITY (continued)

### Internals

The following internal sensors and digital inputs are generated by the strategy and their values can be monitored by text comms (including IC Comms) and LONWORKS® comms (using network variables). Some can be monitored using display and directory modules (e.g. using IQView):

#### Internal Sensors

**S1:** The Space Temperature used by the strategy. It is normally taken from the Local SpaceTemp (S9), but if there is a sensor fault (read or out of limits) it will use the RemoteSpaceTemp (K2). It will also use the RemoteSpaceTemp if the RemoteSpaceTemp is bound to a LONWORKS sensor.

**S2:** The Setpoint used by the strategy. It is the setpoint set by the Remote Setpoint (K1) plus the trim generated by multiplying the Local SP Adjust (S10), by the Offset Range (K15). If the Local SP Adjust has a fault (read or out of limits) it will use the Remote SP Offset (K8) as a trim. It will also use K8 if Remote SP Offset is bound to a LONWORKS sensor

**S3:** The Occupancy state of the IQL, in the range: 0(Occupied), 1(Unoccupied), 2(Bypass), 3(Standby). These states are defined below under Remote Occ (K6). The Remote Occ specifies the occupancy state. The PIR can override from Standby into Bypass; the Pushbutton can override from any state into Bypass. Within the unit Bypass produces the Occupied state. The Window Contact or the Remote Shutdown (W8) will override into Unoccupied.

**S4:** The Heating Demand is the calculated requirement for heating (0 to 100%).

**S5:** The Cooling Demand is the calculated requirement for cooling (0 to 100%).

#### Internal Digital Inputs

**I1:** Fan Enabled, indicates that the Fan is Enabled (i.e. fan is on).

**I2:** Unit Occupied, indicates that the Unit is Occupied (out of box default). It will be true if the Unit is in Bypass or Occupied as dictated by the Remote Occ (K6), and by the Pushbutton or the PIR. It is switched off into Unoccupied by Window Contact, or Remote Shutdown (W8).

**I3:** Unit Unoccupied indicates that the Unit is Unoccupied as dictated by the Remote Occ (K6). The pushbutton can switch the unit from unoccupied to bypass state (equivalent to Unit Occupied), but the Window Contact, or Remote Shutdown (W8) will override to unoccupied.

**I4:** Unit in Bypass indicates that the Unit is in Bypass as dictated by the Remote Occ (K6) or by the pushbutton. Although separately decoded as a state it also produces the Unit Occupied state within the unit so that I2 and I4 exist concurrently. The PIR will override this state to occupied, but the Window Contact (I10), or Remote Shutdown (W8) will override to unoccupied.

**I5:** Unit in Standby indicates the Unit is in Standby as dictated by the Remote Occ (K6). The pushbutton or PIR will override to Bypass. Bypass is treated as Occupied with the unit. It is switched off into Unoccupied by Window Contact (I10), or Remote Shutdown (W8).

### Adjustments

The following switch and knob adjustments can be monitored and changed by text comms (including IC Comms), and by LONWORKS comms (using network variables). Some can be monitored and changed using display and directory modules (e.g. using IQView):

#### Switches

**W1:** This switch, O=4Pipe I=2Pipe, is used to select the strategy type, either 2 pipe (W1=I) or 4 pipe (W1=O). Strategy selection is described in the Changing the Strategy section.

**W2:** This switch, Summer Mode, selects the output used to drive the single valve for 2 pipe strategies. If Winter mode is selected (W2=O, default), the valve is driven from the heating demand, and if Summer mode is selected (W2=I) the valve is driven from the cooling demand.

**W4:** This switch, O=Water I=Air, is used to select the strategy type, either Air (W4=I) or Water (W4=O). Strategy selection is described in the Changing the Strategy section.

**W5:** This switch, Window Mode, selects the Window PB PIR input (IN3) to be a Window contact if set true (W5=I). The window contact opening will then switch the unit into the unoccupied state. If W5=O (default), IN3 can be either a pushbutton or PIR input as selected by W6.

**W6:** This switch, O=Pb I=PIR, selects whether the Pushbutton or PIR input is being used for IN3 as long as the Window Mode switch is set false (W5=O). If W6=I, PIR is selected, if W6=O (default) Pushbutton is selected.

**W7:** This switch, Frost Condition, forces the unit into a Frost Condition during non-occupation if set true (W7=I) and if running a Water side strategy (W4=O). During the frost condition the heating demand is set to 100%. If W7=O (default) the frost condition is turned off

**W8:** This switch, Remote Shutdown, forces the unit into the Unoccupied state disables cooling, only allows sub-zero heating, and disables fabric protection during non-occupation if set true (W8=I). If W8=O (default) the Remote Shutdown is turned off.

#### Knobs

**K1:** This knob, Remote Setpoint (default = /UK/: 20 °C, /USA/UL/: 68 °F), is combined with the Local SP Adjust (S10) to produce the Setpoint (S2). If the Local SP Adjust has an Outside Limits or Read alarm, or if the Remote SP Offset (K8) is bound to a LONMARK sensor (i.e. connected by LONWORKS communications to an output from another LONWORKS device), the Remote SP Offset is used to trim the setpoint instead of the Local SP Adjust.

**K2:** This knob, Remote Space Temp (default = /UK/: 20 °C, /USA/UL/: 68 °F), is used instead of the Local Space Temp (S9) when S9 has an Outside Limits or Read alarm, or if the Remote Space Temp is bound to a LONMARK sensor (i.e. connected by LONWORKS communications to an output from another LONWORKS device).

**K3:** This knob, OCC Deadband (default = /UK/: 1 °C, /USA/UL/: 2 °F), defines the difference between the heating and cooling setpoints during occupation.

**K4:** This knob, Standby Deadband (default = (default = /UK/: 2 °C, /USA/UL/: 4 °F) defines the difference between the heating and cooling setpoints during standby.

**K5:** This knob, NOCC Deadband (default = /UK/: 12 °C, /USA/UL/: 22 °F) defines the difference between the heating and cooling setpoints during non-occupation.

**K6:** This knob, Remote Occ (default = 0, Occupied), defines the unit's occupancy state: 0(Occupied), 1(Unoccupied), 2(Bypass), 3(Standby). It can be overridden into Bypass (equivalent to Occupied within the unit) from any occupation state by the Pushbutton or from Standby by the PIR. The state is overridden to Unoccupied by the Remote Shutdown (W8), or the Window Contact.

**Occupied:** The fan is on, if in auto, and Cool outputs are enabled if the fan is on. Heat outputs are enabled anyway. The Occupation Deadband (default /UK/: 1 °C, /USA/UL/: 2 °F) is used.

**Unoccupied:** Heating is enabled and the Non-occupied Deadband (default /UK/: 12 °C, /USA/UL/: 22 °F) is used. The fan is normally off, but Fabric protection will bring it on. The Frost Condition W7 will override the heating to 100%. If the fan is on Cooling is enabled.

**Bypass:** This effectively produces the same state as occupied but it is intended to be used for a short time only. If the bypass state is produced (either by Remote Occ, K6, pushbutton, or PIR) it will produce the occupied state inside the unit, although Occupancy (S3) will show the bypass state.

**Standby:** The fan and heat and cool outputs operate as for occupied. It is designed to reduce energy consumption in the zone (Standby Deadband defaults to /UK/: 2 °C, /USA/UL/: 4 °F). The unit is put back into occupation by PIR, or by pushbutton (using Bypass).

**K8:** This knob, Remote SP Offset (default = /UK/: 0 °C, /USA/UL/: 0 °F), is added to the Remote Setpoint (K1) instead of the Local SP Adjust (S10) if the Local SP Adjust has an Outside Limits or Read alarm, or if the Remote SP Offset (K8) is bound to a LONMARK sensor (i.e. connected by LONWORKS communications to an output from another LONWORKS device).

#### Knobs (non LONWORKS comms.)

These knobs can only be adjusted by text comms (including IC Comms), not LONWORKS comms:

**K13:** This knob, Pb PIR Run On (default = 1800 s), sets the time for which the pushbutton or PIR inputs override the unit to the occupied state. (Pushbutton overrides via the Bypass state.)

**K15:** This knob, Offset Range (default = /UK/: 2 °C, /USA/UL/: 2 °F), is used to define the range of the Local SP Adjust (S10). The Local SP Adjust is scaled to give a value in the range -½ to +½. This is multiplied by the Offset Range to give the setpoint trim which is applied to the Remote Setpoint (K1) to produce the Setpoint (S2).

**FUNCTIONALITY** (continued)**Parameters**

The following parameters may be required to be changed by text comms:

**L1(G),L1(I)**. The heating loop gain (default 20) and integral (default 20 mins) may need to be tuned for optimum performance.

**L2(G),L2(I)**. The heating loop gain (default 20) and integral (default 20 mins) may need to be tuned for optimum performance.

**Text Comms**

The item values can be monitored or changed using text comms as described in the IQ system LONWORKS Products Engineering Manual (TE200292). The value of a sensor or knob is referred to by **V**, and the status of an input or switch is referred to by **S**. e.g. **S1(V)** gets value of S1, **W1(S=I)** sets switch 1 on. Some of the other parameters are:

**S**ensor, **K**nob, **sW**itch, **D**river, **I**nput, **d**irectory **@**: labels (**\$**)

**S**ensor, **K**nob: units (%)

**K**nob: (**T**)op of range, (**B**)ottom of range

**S**ensor: (**O**)ffset

**D**river: (**P**)eriod, fullscale (**D**)rive time, **t(Y)**pe

**P**lot: (**S**)ensor number, (**P**)eriod (P=0: 1h, 1:15m, 2:24h, 3:1m, 4:5m, 6:20m, 7:30m, 8:6h)

**D**isplay ~: (**I**)tem

**L**oop: (**I**)ntegral, (**G**)ain, and (**R**)eschedule times

(**L**o**G**ic): o(**N**)delay, (**M**)inimum on time, o(**F**)f delay

**F**unction: (rescale to, rescale from only), **E**, **F** rescale limits

**I**C Comms **N**: remote device (**A**)ddress, attri(**B**)ute, remote la(**N**), (**I**)nterval, (**S**)ignificant change, source ite(**M**), d(**E**)stination module no., destination i(**T**)em

**Water Balancing**

The raise/lower (floating point) and time proportional outputs are set to 100% by sending the text comms message R(#=0). The output will remain set to drive at 100% (even if the power is switched off and on) until the IQL receives a Text comms message R(#=1).

*Note that raise/lower (floating point) drivers will remain in their positions when power is removed, whereas time proportional drivers will close.*

This enables the heating and cooling valves to be fully opened for balancing and flushing of a water side system (applies to /WR2, /WR4, /WT2, /WT4 strategies). It should not be used on an airside system (e.g. /AR2).

*Note that time proportional outputs will not open together; the heat output will open first, then the cool output 10 seconds later, to reduce the peak current consumed.*

**LONWORKS Comms**

The nv name is the name given to the particular item for identification by a LONWORKS network management tool. The IQL can communicate with other LONMARK devices via Network Variables (NVs) if their items are bound together by the tool, see IQ system LONWORKS Products Engineering Manual (TE200292).

**Display and Directory modules**

There are 3 directory modules with 20 display modules. See IQ system LONWORKS Products Engineering Manual for use of these modules.

Directory	Label	Display	Item
1	Overview	1	I2 Unit Occupied
		2	I3 Unit Unoccupied
		3	S1 Space Temp
		4	S2 Setpoint
		5	S4 Heating Demand
		6	S5 Cooling Demand
		8	I1 Fan Enabled
		2	Details
10	I5 Unit in Standby		
11	S9 Local Space Temp		
12	S10 Local SP Adjust		
13	I9 Window PB PIR		
3	Commissioning	14	K1 Remote Setpoint
		15	K2 RemoteSpace Temp
		16	K3 OCC Deadbnd
		17	K4 Standby Deadbnd
		18	K5 NOCC Deadbnd
		19	K6 Remote Occ
		20	W5 Window Mode
		21	W6 PIR Pb Select

**Plot**

The single plot channel is set to plot the Space Temp sensor S1 at 15 min intervals (80 readings). It can be changed by text comms - see above.

## STRATEGY

### BRIEF DESCRIPTION

The strategy controls a fan coil unit with heat/cool outputs (dependent on strategy type), and an on/off fan in response to a thermistor temperature sensor reading. A local setpoint adjustment can trim the setpoint. A window contact, pushbutton, or PIR (Passive Infra Red movement detector) input can override the occupation state.

The controller maintains the temperature of a space to the defined setpoint. The plant diagrams on the first page illustrate typical controller applications for the standard strategies available. The control is achieved by modulating the heat/cool output(s) based on the current space requirements.

The controller operates in either Occupied, Unoccupied, Bypass, or Standby modes as determined by the **Remote OCC** setting. The controller maintains the comfort level to a user-defined setpoint.

The controller switches the supply air fan on or off. The fan will be running during occupation, and if there is a heating demand during non-occupation.

During non-occupation the unit will detect the temperature falling below the required temperature and switch on the fan (**Fabric protection**).

Also during non-occupation the remote **Frost Condition** setting will override the heating to 100% (water side only, not /AR2).

The heating is enabled all the time whereas the cooling is enabled whenever the fan is running.

The occupancy override pushbutton will switch the unit into bypass from any occupation state. A PIR (occupation sensor) will switch the unit into bypass from standby. Within the unit bypass is effectively the same as occupied.

The Window Contact or the **Remote Shutdown** setting will set the unit into Unoccupied, disable cooling, only allow heating for sub-zero temperatures, and stop fabric protection.

For 2 pipe strategies the controller can control heating only or cooling only as defined by the **Summer Mode** setting; if set to Winter (O) the controller controls heating only.

When cooling, the cooling output is calculated by a proportional + integral control loop based on the space temperature and the cooling setpoint. As the temperature rises above the cooling setpoint the cooling output will be increased. The cooling output will be decreased as the temperature falls below the cooling setpoint. When unoccupied, the cooling setpoint will be increased.

When heating, the heating output is calculated by a proportional + integral control loop based on the space temperature and the heating setpoint. As the temperature falls below the heating setpoint the heating output will be increased. The heating output will be decreased as the temperature rises above the heating setpoint. When unoccupied, the heating setpoint will be decreased.

The actual cool and heat setpoints are set above and below the user-defined setpoint by half the current deadband. The deadband is increased during non-occupation by having different deadbands for the operating modes, i.e. **OCC Deadbnd** (used for Occupied and Bypass modes), **Standby Deadbnd**, and **NOCC Deadbnd**.

The inputs (except for a window contact or PIR) can be provided by TB/TS/KE or RD-IQL/KOS products. The RD-IQL/KOS, Room Display, includes a space temperature sensor, local setpoint adjust increase and decrease buttons, and an occupancy override button. It can display either local temperature or setpoint, and fan and occupation state icons.

The **Local SP Adjust** and **Local Space Temp** inputs generate both Read and Outside Limits alarms. The read alarm indicates a problem with the controller, and the Outside Limits alarm indicates that the input signal is outside its expected range. An alarm message will be sent both when an alarm condition is detected and when it is cleared if the alarm is enabled by text comms.

The window Pb PIR input can be enabled by text comms to generate an alarm either on input contact closures or openings.

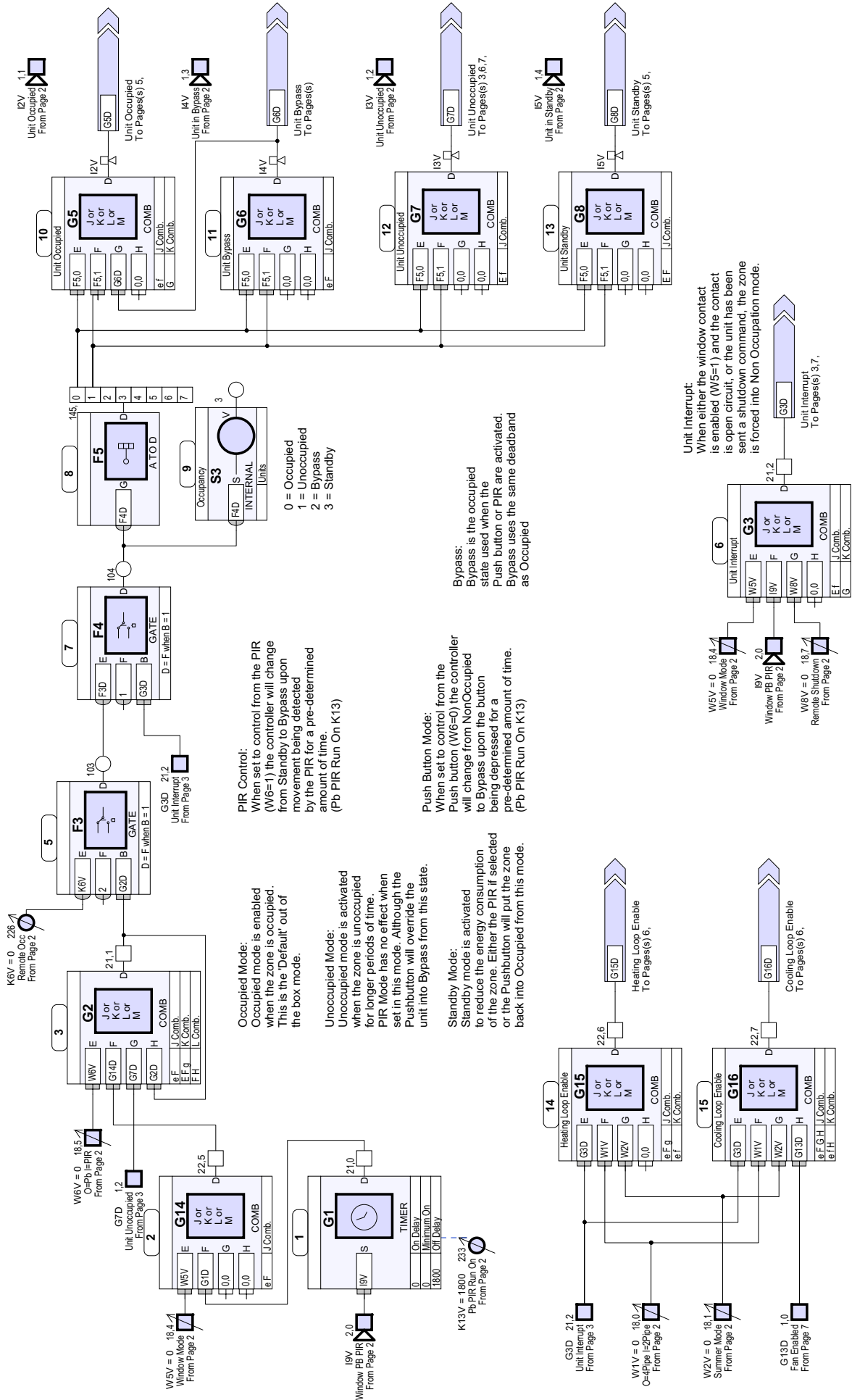

**PIR Control:**  
When set to control from the PIR (W6=1) the controller will change from Standby to Bypass upon movement being detected by the PIR for a pre-determined amount of time. (Pb PIR Run On K13)

**Occupied Mode:**  
Occupied mode is enabled when the zone is occupied. This is the 'Default' out of the box mode.

**Unoccupied Mode:**  
Unoccupied mode is activated when the zone is unoccupied for longer periods of time. PIR Mode has no effect when set in this mode. Although the Pushbutton will override the unit into Bypass from this state.

**Standby Mode:**  
Standby mode is activated to reduce the energy consumption of the zone. Either the PIR if selected or the Pushbutton will put the zone back into Occupied from this mode.

**Push Button Mode:**  
When set to control from the Push button (W6=0) the controller will change from NonOccupied to Bypass upon the button being depressed for a pre-determined amount of time. (Pb PIR Run On K13)

**Unit Interrupt:**  
When either the window contact is enabled (W6=1) and the contact is open circuit, or the unit has been sent a shutdown command, the zone is forced into Non Occupation mode.

Occupation (Diagram 1, strategy page 3)

## DETAILED DESCRIPTION

This section describes the strategy in detail.

*Note that the strategy diagrams have been produced with SET using standard IQ controller nodes. Other than the nodes associated with knobs, switches, sensors, and digital inputs, the remaining nodes are not implemented in the IQL so should be ignored; also note that knobs 1 to 16 are associated with nodes A17 to A32 which is different to normal IQs.*

### Occupation (Diagram 1, strategy page 3)

#### Summary

The controller operating mode is set by **Remote Occ** (K6) to Occupied, Unoccupied, Bypass, or Standby. The operating mode can be monitored by the **Occupancy** sensor (S3) or from the **Unit Occupied** (I2), **Unit Unoccupied** (I3), **Unit in Bypass** (I4), and **Unit in Standby** (I5) internal digital states.

The **Pushbutton** (I9) forces the unit into Bypass from any state for the **Pb PIR Run On** time (defined by K13, default 1800 s=30 mins). The **PIR detector** (I9) will override the unit from Occupied or Standby into Bypass for at least the **Pb PIR Run On** time (defined by K13, default 1800 s=30 mins). Within the unit, the Bypass condition is treated the same as Occupied so that although S3 shows separate Occupied and Bypass states, if Bypass is set, then both I4 (Bypass) and I2 (Occupied) will be set.

The **Remote Shutdown** (W8) or **Window Contact** (I9) will override the unit into Unoccupied and disable the heating and cooling loops. Otherwise the heating loop is enabled during Winter for a 2 pipe strategy, and all the time for a 4 pipe strategy, while the cooling loop is enabled if the fan is enabled, during summer for a 2 pipe strategy, and all the time for a 4 pipe strategy.

#### Detail

The Remote Occ state knob, K6, is set to either 0(Occupied), 1(Unoccupied), 2(Bypass), or 3(Standby) and is normally connected by way of F3 and F4 to the A to D module F5 whose input is monitored by the Occupancy Sensor S3. The 2 digital bits output by F5 are further decoded by logic modules G5, G6, G7, and G8 respectively to produce the outputs, Unit Occupied (I2), Unit in Bypass (I4), Unit Unoccupied (I3) and Unit in Standby (I5). Note that although S3 will monitor the separate Bypass (S3=2) state, G5 produces the Occupied state if Bypass is set so that within the rest of the strategy these two states are treated the same.

The combined Window PB PIR input (I9) initiates a pulse at the output of G1 for a minimum time defined by the off delay set by K13, Pb PIR Run On time, (default 1800 s=30 mins).

If Window Mode is not selected (W5=0), G14 passes this on to G2.

If O=Pb I=PIR, W6=0, the Pushbutton or PIR input (I9) is treated as Pushbutton, and G2 passes the pulse through to F3 which overrides the occupation state to 2 (Bypass). Thus the pushbutton will override the occupation state to Bypass (equivalent to Occupied in the strategy).

If O=Pb I=PIR, W6=1, the Pushbutton or PIR input (I9) is treated as PIR, and G2 allows the pulse through if the unit is not unoccupied (i.e. Occupied, Bypass, or Standby). The PIR pulse will cause F3 to override the occupation state to 2 (Bypass). Thus the PIR sensor will override the occupation state to Bypass (equivalent to Occupied in the strategy) from Occupied, Bypass, or Standby but will not affect an Unoccupied state.

If either the Remote Shutdown W8 is present, or the Window PB PIR input (I9) is open (and Window Mode is selected by W5=0), the output of G3 will override the occupancy state by way of F4 to Unoccupied, 1.

With the output of G3 false, the output of G15 enables the heating loop either for a 2 pipe strategy in Winter mode, or a 4 pipe strategy all the time. Also with the output of G3 false and with the fan enabled, G16 enables the cooling loop either for a 2 pipe strategy in Summer mode, or for a 4 pipe strategy all the time.

The Window Pb PIR input (I9) can be enabled to generate an alarm by text comms parameter I9(e).

e=0 or 1, alarm disabled

e=2 alarm enabled, required value =0

e=3 alarm enabled, required value =1

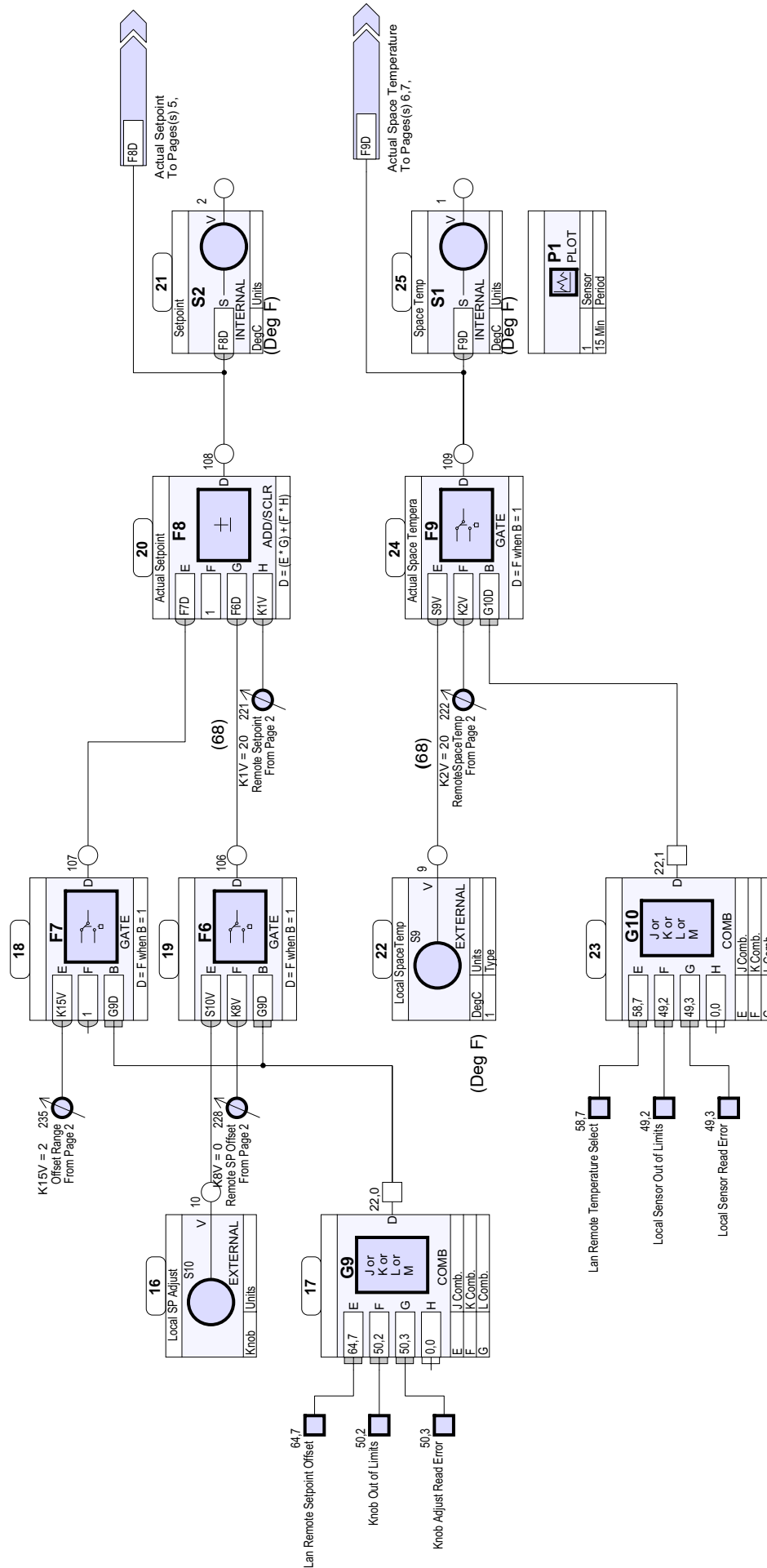

changes for /USA/UL/ strategy shown in brackets

Setpoint and Details (Diagram 2, strategy page 4)

**Setpoint and Details** (Diagram 2, strategy page 4)

Summary:

**Setpoints**

The **Local SP Adjust** is scaled within the unit to produce a value in the range  $-\frac{1}{2}$  to  $+\frac{1}{2}$ . This is multiplied by the **Offset Range** (default /UK/: 2°C, /USA/UL/: 2°F) to produce a trim (default /UK/: -1°C to +1°C, /USA/UL/: -1°F to +1°F). This trim is added to the **Remote Setpoint** (default /UK/:20 °C, /USA/UL/: 68 °F) to produce the **Setpoint**.

$$\text{Setpoint} = \text{Local Setpoint Adjust} \times \text{Offset Range} + \text{Remote Setpoint}$$

If the **Remote SP Offset** is bound to a LONWORKS device, then the Remote SP Offset is added to the Remote Setpoint to produce the Setpoint. The Remote SP Offset is also used if Local SP Adjust has a Read or Out of Limits alarm condition

$$\text{Setpoint} = \text{Remote Setpoint Offset} + \text{Remote Setpoint}$$

**Space Temperature**

The **Space Temp** is normally the **Local Space Temp**, but if the **RemoteSpaceTemp** is bound to a LONWORKS device, it is used instead. The **RemoteSpaceTemp** is also used if the **Local Space Temp** has a Read or Out of Limits alarm condition.

**Detail:**

The real sensor S10 monitors the Local SP Adjust potentiometer (0 to 1) and adds offset (default  $-\frac{1}{2}$ ) to produce S10 output ( $-\frac{1}{2}$  to  $+\frac{1}{2}$ ). Function module F6 normally connects the adjustment to F8 where it is multiplied by the Offset Range K15 (default /UK/: 2 °C, /USA/UL/: 2 °F) and added to the Remote Setpoint K1 (default /UK/:20 °C, /USA/UL/: 68 °F). This produces the actual setpoint monitored by Setpoint sensor S2.

If the Remote SP Offset K8 is bound to a LONWORKS device, then Lan Remote Setpoint Offset bit 64.7 is set true. If either this is true, or the Local Setpoint Adjust knob is Out of Limits or has a Read error, then the Remote SP Offset is gated through to F8 by F6, and the range from F7 is set to 1, with the result that F8 adds the Remote SP Offset to the Remote Setpoint. Thus Remote SP Offset K8 can either be a knob fail default, or it can be a value bound to a LONMARK device.

The Space Temp (S1) is normally the Local Space Temp (S9) via F9 but if the RemoteSpaceTemp K2 is bound to a LONWORKS space sensor, the Lan Remote Temp Select bit 58,7 is set true and logic module G10 causes S1 to be the RemoteSpaceTemp K2. This will also happen if Local Space Temp has a Read or Out of Limits error. Thus RemoteSpaceTemp K2 can either be a sensor fail default, or it can be a value bound to a LONMARK sensor.

**Deadbands/Heating & Cooling Setpoints** (Diagram 3, strategy page 5)

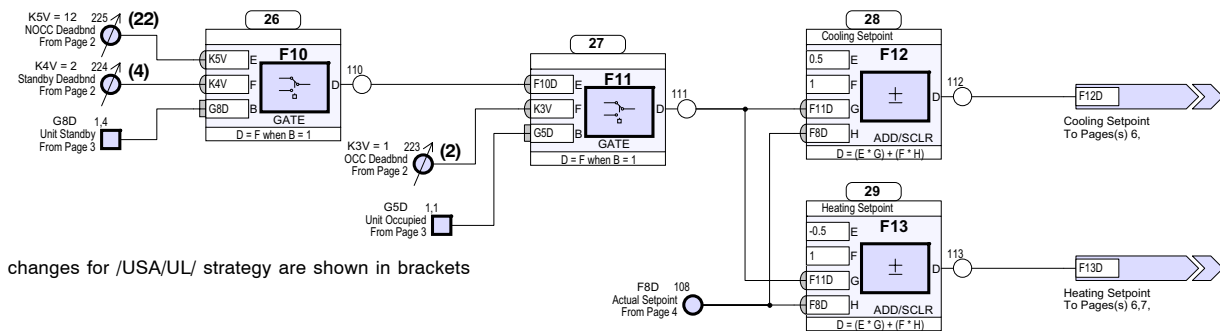

changes for /USA/UL/ strategy are shown in brackets

**Summary:**

The current deadband is selected from the NOCC deadband (default /UK/: 12 °C, /USA/UL/: 22 °F), Standby Deadband (default /UK/: 2 °C, /USA/UL/: 4 °F), OCC Deadband (default /UK/:1 °C, /USA/UL/: 2 °F) according to the unit's occupancy state.

The Heating Setpoint is the **Setpoint** minus half the current deadband, and the Cooling Setpoint is the **Setpoint** plus half the current deadband.

$$\text{Heating Setpoint} = \text{Setpoint} - \frac{1}{2}(\text{deadband})$$

$$\text{Cooling Setpoint} = \text{Setpoint} + \frac{1}{2}(\text{deadband})$$

**Details:** The function modules F10 and F11 produce a deadband according to the unit state; if Unit Occupied is true, the OCC Deadband K3 (default /UK/: 1 °C, /USA/UL/: 2 °F) is selected, if Unit in Standby is true, the Standby Deadband K4 (default /UK/: 2 °C, /USA/UL/: 4 °F) is selected, and if otherwise i.e. non-occupied, the NOCC Deadband K5 is selected (default /UK/: 12 °C, /USA/UL/: 22 °F).

The function modules F12 and F13 add and subtract half the deadband from the Actual Setpoint to produce the Heating (F12) and Cooling (F13) loops' Setpoints respectively.

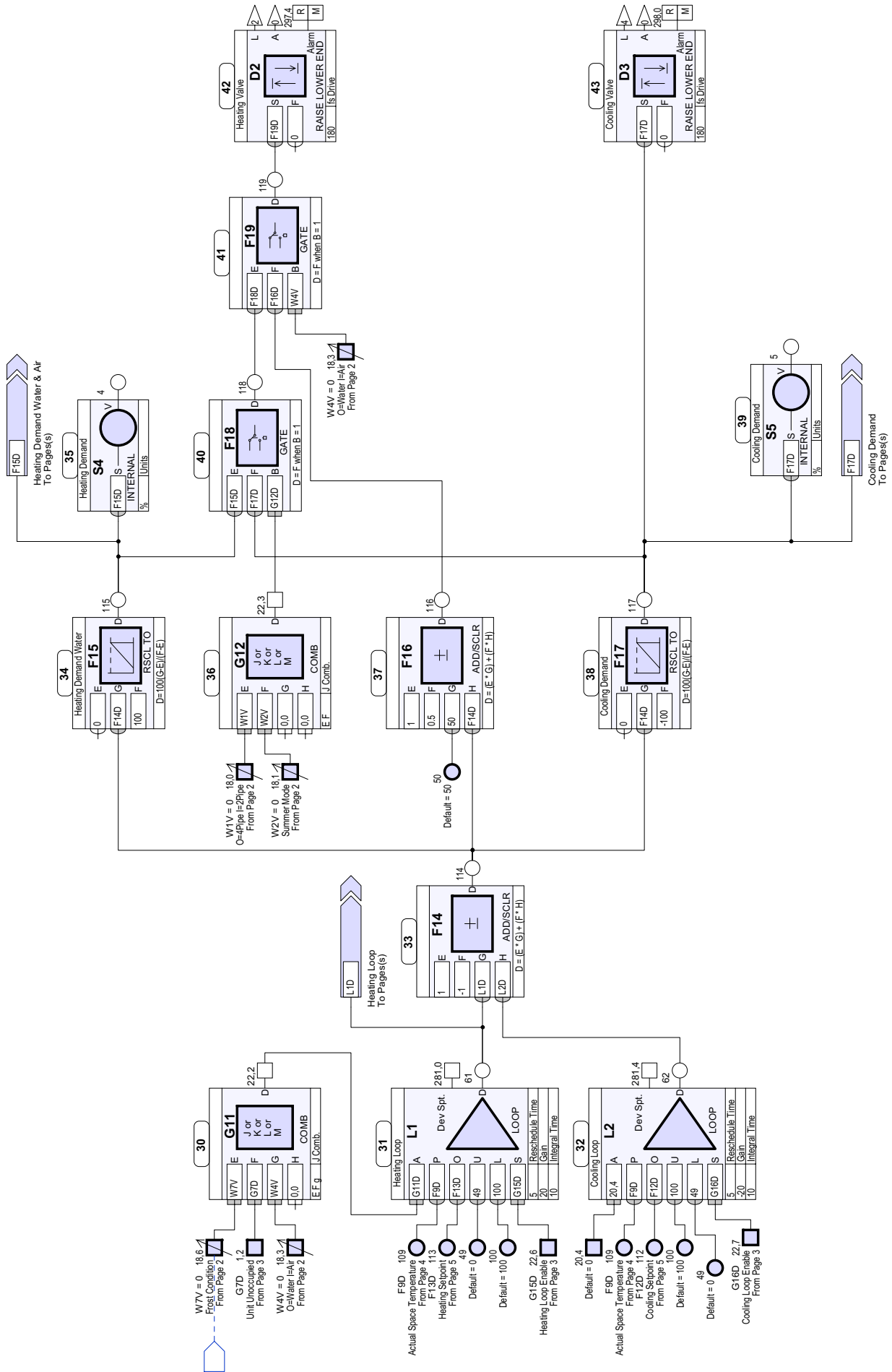

Heat/Cool Control (Diagram 4, strategy page 6)

Summary:

Heat and Cool Loops

The heating and cooling sides are controlled by different control loops.

The Heating Loop is enabled for a 2 pipe strategy in Winter mode, or for a 4 pipe strategy all the time, The Cooling Loop is enabled if the fan is running for a 2 pipe strategy in Summer mode, or for a 4 pipe strategy all the time. If the Heating Loop is disabled, its setpoint is set to zero. If the Cooling Loop is disabled, the output is effectively set to zero. The **Remote Shutdown** or enabled **Window Contact** disable both loops.

The Heating Loop compares the **Space Temp** with the heating setpoint. The proportional + integral (P+I) loop will modulate the heating output to maintain a constant space temperature. As the temperature decreases below the heating setpoint the heating output will modulate open. The heating output will be modulated closed as the temperature increases above the heating setpoint. When the unoccupied mode is entered the heating loop's setpoint is decreased by the deadband mechanism explained above. The loop output is limited to the range 0 to 100%.

The Cooling Loop compares the **Space Temp** with the cooling setpoint. The proportional + integral (P+I) loop will modulate the cooling output to maintain a constant space temperature. As the temperature increases above the cooling setpoint the cooling output will modulated open. The cooling output will be modulated closed as the temperature decreases below the cooling setpoint. When the unoccupied mode is entered the cooling loop is disabled and its output is set to zero. The loop output is limited to the range 0 to 100%.

Error, E = setpoint - **Space Temp**

$$LoopOutput = G(E) + \int \frac{G(E)}{I} dt$$

Where G = Loop gain  
I = Integral time constant

The integral time constant is the time for which the loop output will have added to it an amount equal to product of the error and the gain (i.e. equal to the proportional part) under conditions of constant error. So if the error stays the same for the integral time constant, the loop output will double and will be 2G(E).

The loops have the following default settings :heat loop gain = 20, cool loop gain = -20, both loop integral time constants =10 mins. These settings can be changed by text comms.

The output from the loops (ignoring the integral action) is illustrated by the chart below :

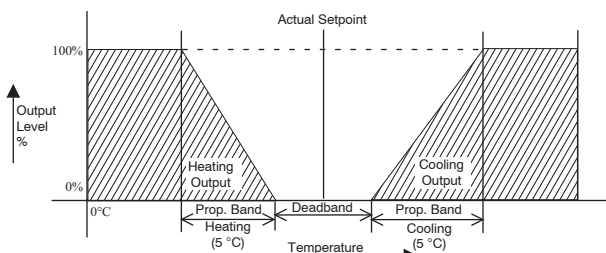

The heating loop will not operate until the **Space Temp** drops below the **Setpoint** by half the deadband (e.g. default = /UK/: 20-0.5 = 19.5 °C; /USA/UL/: 68-1 = 67 °F during occupation). Similarly for cooling it must rise above by half the deadband. The loop gains are set to ±20 by default which gives proportional bands of 100/20 = (/UK/: 5 °C, /USA/UL/: 5 °F). When set to defaults, during occupation, this will give 100% heat at /UK/: 14.5 °C, /USA/UL/: 62 °F, and 100% cool at /UK/: 25.5 °C, /USA/UL/: 74 °F (ignoring the effect of the integral term).

The heating loop is overridden to 100% if the **Frost Condition** is set during non-occupation) and the unit is running a water side strategy. This will bring on maximum heating.

The loop outputs are added together and then split into separate heating and cooling outputs to prevent simultaneous heating and cooling. The combined and separate heat and cool outputs are selected to drive the 4 output channels (4, 5, 6, 7) as required by the strategy type by the switches **O=4Pipe I=2ipe** (W1), **O=Water I=Air** (W4), and **Summer Mode** (W2). The driver type is also changed according to the strategy.

For the airside strategy (/AR2) the combined heating and cooling output drives the heat/cool damper.

For a 4 pipe strategy (/WR4, WT4) the heating output drives the heating valve and the cooling output drives the cooling valve.

For a 2 pipe strategy (/WR2, WT2), the heat or cool valve demand comes from the heating loop in the winter, and the cooling loop in the summer as set by the Summer Mode setting.

Detail:

When the loops are disabled by means of the setpoint selection, S, inputs, the heating and cooling, U, setpoints are set to 0 and 100 respectively. This ensures that the heating loop output will not rise unless the temperature drops below /UK/: 0 °C, /USA/UL/: 0 °F and the cooling loop output will not rise (unless the temperature exceeds /UK/: 100 °C, /USA/UL/: 100 °F).

If the Frost Condition is set (W7=I), and the unit is Unoccupied with a Water side strategy (W4=O), the output of G11 forces the heating loop into manual via its A input which cause the output to equal its L input, i.e. 100% heating.

The heating and cooling loop outputs are added by F14 to give -100 to +100 maximum cool to maximum heat. They are then rescaled by modules F15 and F17 so that F14 output of 0 to +100 gives Heating Demand (S4), 0 to 100%, and F14 output of -100 to 0 gives Cooling Demand (S5), 100 to 0%. Combining the loop outputs in this way prevents simultaneous heating and cooling. The Cooling Demand drives the cooling output via driver D3.

The Heating Demand is connected directly to the heating output via F18, F19, and driver D2 if the strategy is 4 pipe (W1=O) and Water side (W4=O) i.e /WR4 or /WT4.

If the strategy is 2 pipe (W1=I) and Summer Mode switch is set to Summer (W2=I), the output of G12 will cause F18 to gate the cooling demand through to the 'heating' output, i.e for /WR2 or /WT2.

The combined output of -100 to +100 from F14 is scaled by F16 to 0 to 100 (maximum cool to maximum heat) i.e. 50% is no heating or cooling. This is switched through to the heating output if the strategy is Airside (W4=I) i.e. for /AR2 strategy.

The D2 and D3 driver types, their function, and the output channels used, vary with the strategy type as shown in the table below. The strategy may be changed using text comms as detailed in the Changing the Strategy section (page 15).

Strategy	D2			D3		
	Type	Channels used	Function	Type	Channels used	Function
AR2	4 Raise/Lower (floating point)	2, 3	Heat/cool damper	0	not used	not used
WR2	4 Raise/Lower (floating point)	2, 3	Heat or cool valve	0	not used	not used
WR4	4 Raise/Lower (floating point)	2, 3	Heat valve	4 Raise/Lower (floating point)	4, 5	Cool Valve
WT2	3 Time Proportional	2	Heat or cool valve	0	not used	not used
WT4	3 Time Proportional	2	Heat valve	3 Time Proportional	4	Cool valve

Note that after a reset (power or programmed) and at midnight each Raise/Lower (floating point) driver will recalibrate the valve or damper position by driving the valve or damper to the calculated zero position (fully closed) and then over drive for one complete driver period, (full scale drive time) to ensure the valve or damper is fully closed. It will then drive the valve or damper to the position required by the calculated demand.

Fan Control (Diagram 6, strategy page 7)

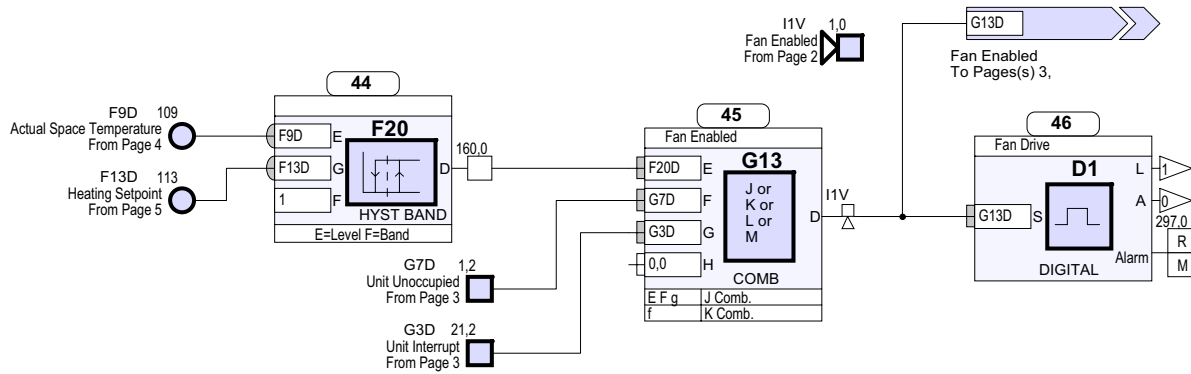

Summary:

While occupation state is **Unit Unoccupied** the fan is normally switched off. It comes on for building fabric protection if the temperature falls below the heating setpoint by 0.5 (default= /UK/:20-6-0.5=13.5 °C, /USA/UL/: 68-11-0.5=56.5 °F). The fan will be switched off as the temperature rises above the heating setpoint by 0.5 (default= /UK/: 14.5 °C, /USA/UL/: 57.5 °F). The **Window Contact** or **Remote Shutdown** will override the fabric protection off.

During any other occupation state (**Occupied, Bypass, Standby**) the fan will be on.

Detail:

Fabric protection during non-occupation is provided by F20. If the actual Space Temperature falls below the Heating Setpoint by (/UK/: 0.5 °C, /USA/UL/: 0.5 °F), F20 output goes true and switches the fan on via G13.

As the Actual space temp rises above the heating setpoint by (/UK/: 0.5 °C, /USA/UL/: 0.5 °F) the output of F20 will go to zero and switch the fan back off.

G13 will switch the fan on via driver D1 if the fabric protection is on while the unit is unoccupied as long as the Unit Interrupt is not present. If the Window contact or Remote Shutdown operate the Unit interrupt will cause the G13 output to be zero and will switch off the fabric protection strategy.

The output of G13 is also true if Unit Unoccupied is false, so the fan is on during Occupied, Bypass, and Standby states.

The digital fan driver D1 drives the fan via channel 1

Changing the Strategy

The IQL strategy can be changed using the Switches, **O=4Pipe I=2Pipe** (W1), and **O=Water I=Air** (W4), and the drivers D2 and D3. These changes are made more easily using the 'Strategy Type' feature in IqlTool2. If not using IqlTool2, the changes can be made using a suitable IQ system tool and the terse text communications strings shown below:

The following strings should be used:

```
/AR2
D2($="Damper",Y=4),D3($="Dummy",Y=4),W1(S=O),W4(S=I),R(z=1)
wait 10 s
D2(D=180),D3(D=180),R(z=1)
```

Note that although AR2 implies 2 pipe, both heat and cool loops need to be enabled for the airside strategy, hence W1=O, 4 pipe.

```
/WR2
D2($="Heat Cool Valve",Y=4),D3($="Dummy",Y=4),W1(S=I),W4(S=O),R(z=1)
wait 10 s
D2(D=180),D3(D=180),R(z=1)
```

```
/WR4
D2($="Heating Valve",Y=4),D3($="Cooling Valve",Y=4),W1(S=O),W4(S=O),R(z=1)
wait 10 s
D2(D=180),D3(D=180),R(z=1)
```

```
/WT2
D2($="Heat Cool Valve",Y=3),D3($="Dummy",Y=3),W1(S=I),W4(S=O),R(z=1)
wait 10 s
D2(P=100),D3(P=100),R(z=1)
```

```
/WT4
D2($="Heating Valve",Y=3),D3($="Cooling Valve",Y=3),W1(S=O),W4(S=O),R(z=1)
wait 10 s
D2(P=100),D3(P=100),R(z=1)
```

## Using RD-IQL

The IQL11+ is compatible with RD-IQL/K, /KOS but not /KOSF).

The parameters changed by the RD-IQL are:

**S9, Local Space Temp** (RD-IQL/K, /KOS)  
**S10, Local SP Adjust** (RD-IQL/K, /KOSF)  
**I9, Pushbutton PIR** (RD-IQL/KOS)

The parameters displayed on the RD-IQL are:

**S1, Space Temp** (RD-IQL/K, /KOS)  
**S2, Actual Setpoint** (RD-IQL/K, /KOS)  
**S3, Occupancy** (RD-IQL/KOS)

The IQL must be set up to use the RD. The changes are made easily using the 'Configure for RD-IQL' features in IqlTool2. If not using IqlTool2, the changes can be made using a suitable IQ system tool and the terse text communications strings shown below:

The IQL must be set up as follows:

Local Space Temp Type, **S9(Y=6)** (use RD)  
 Local SP Adjust Type, **S10(Y=6)** (use RD)  
 Window Mode, **W5(S=O)** (Pushbutton or PIR, default)  
 O=Pb I=PIR, **W6(S=O)** (Pushbutton selected, default)

This should be terminated by a text comms reset command R(z=1) to write changes to flash and reset the unit; note that this command clears logged data and sets time to zero.

It is possible to use the RD in conjunction with a separate temperature sensor connected to IN1. To do this, leave Local Space Temp Type as default, S9(Y=1). It is recommended to configure the RD to 'Use local thermistor' so that it displays the correct temperature value.

---

## INSTALLATION

The IQL11+/xxx/24VAC installation is covered by the IQL11+/xxx/24VAC Installation Instructions TG200233 and the IQL11+/xxx/230 installation is covered by the IQL11+/xxx/24VAC Installation Instructions TG200392 .

---

## ORDER CODES

<b>IQL11+/AR2/24VAC</b>	IQL11+ with Airside, Raise/Lower (floating point) Strategy and 24 Vac supply
<b>IQL11+/AR2/230</b>	IQL11+ with Airside, Raise/Lower (floating point) Strategy and 230 Vac supply
<b>IQL11+/WR2/24VAC</b>	IQL11+ with Water Side, 2 Pipe, Raise/Lower (floating point) Strategy and 24 Vac supply
<b>IQL11+/WR2/230</b>	IQL11+ with Water Side, 2 Pipe, Raise/Lower (floating point) Strategy and 230 Vac supply
<b>IQL11+/WR4/24VAC</b>	IQL11+ with Water Side, 4 Pipe, Raise/Lower (floating point) Strategy and 24 Vac supply
<b>IQL11+/WR4/230</b>	IQL11+ with Water Side, 4 Pipe, Raise/Lower (floating point) Strategy and 230 Vac supply
<b>IQL11+/WT2/24VAC</b>	IQL11+ with Water Side, 2 Pipe, Thermic Strategy and 24 Vac supply
<b>IQL11+/WT2/230</b>	IQL11+ with Water Side, 2 Pipe, Thermic Strategy and 230 Vac supply
<b>IQL11+/WT4/24VAC</b>	IQL11+ with Water Side, 4 Pipe, Thermic Strategy and 24 Vac supply
<b>IQL11+/WT4/230</b>	IQL11+ with Water Side, 4 Pipe, Thermic Strategy and 230 Vac supply
<b>IQL11+/AR2/USA/UL/24VAC</b>	IQL11+ with Airside, Raise/Lower (floating point) Strategy and 24 Vac supply. USA version. UL rated.
<b>IQL11+/WR2/USA/UL/24VAC</b>	IQL11+ with Water Side, 2 Pipe, Raise/Lower (floating point) Strategy and 24 Vac supply. USA version. UL rated.
<b>IQL11+/WR4/USA/UL/24VAC</b>	IQL11+ with Water Side, 4 Pipe, Raise/Lower (floating point) Strategy and 24 Vac supply. USA version. UL rated.

## SPECIFICATIONS

### Electrical

Supply	
/230	:230 Vac -10% +15%, 50/60 Hz
/24VAC	:24 Vac $\pm$ 15%, 50/60 Hz
Power	
/230	:Up to 13 VA which consists of 3 VA internal power plus power to 24 Vac auxiliary and triac outputs
/24VAC	:Up to 12.1 VA which consists of 2.5 VA internal power plus power to triac outputs. In both cases the maximum shared between 24 Vac auxiliary and triac outputs used (and 24 Vac auxiliary output for /230 version) is 400 mA.

### Inputs

IN1	
/230	:Thermistor input (S9). Scaled for standard IQ system thermistor (10 k $\Omega$ at 25 °C, 77 °F). Scaling range 2.5 °C to 60 °C (36 °F to 116 °F). Conversion accuracy $\pm$ 0.25 °C ( $\pm$ 0.45 °F) over range (10 to 30 °C, 50 °F to 86 °F).
/24VAC	:Potentiometer Input (S10). Potentiometer input range (1 to 11 k $\Omega$ ) has 0.1% resolution. Self calibrating 0 to 100 % over range used. Gives trim 0 to 1, which is added to sensor offset = (default - 1/2) to give range (default - 1/2 to +1/2); this is multiplied by Offset Range (K15, default /UK/: 2 °C, /USA/UL/: 2 °F) to produce trim on setpoint (default /UK/: -1 °C to +1 °C, /USA/UL/: -1 °F to +1 °F).
IN2	
/230	:Potentiometer Input (S10). Potentiometer input range (1 to 11 k $\Omega$ ) has 0.1% resolution. Self calibrating 0 to 100 % over range used. Gives trim 0 to 1, which is added to sensor offset (default - 1/2) to give range (default - 1/2 to +1/2); this is multiplied by Offset Range (K15, default /UK/: 2 °C, /USA/UL/: 2 °F) to produce trim on setpoint (default /UK/: -1 °C to +1 °C, /USA/UL/: -1 °F to +1 °F).
/24VAC	:Thermistor input (S9). Scaled for standard IQ system thermistor (10 k $\Omega$ at 25 °C, 77 °F). Scaling range 2.5 °C to 60 °C (36 °F to 116 °F). Conversion accuracy $\pm$ 0.25 °C ( $\pm$ 0.45 °F) over range (10 to 30 °C, 50 °F to 86 °F).
IN3	:Window contact, Pushbutton or Passive Infra Red movement detector contact Input (I9). (Volt free contact input. 5 Vdc supply through 10 k $\Omega$ . Wetting current 0.5 mA.) Input is either a window contact, pushbutton, or Passive Infra Red (PIR) movement detector. The window contact will switch off the fan and the heat/cool outputs when the contact is opened (window is opened) for at least 1 second. The pushbutton or PIR detector will bring the fan and the heat/cool outputs into operation when the contact is closed for at least 1 second (dependent on unit state). Input can be used for connection of RD-IQL with following options: RD-IQL/K provides thermistor temperature sensor and setpoint trim. RD-IQL/KOS provides the same as RD-IQL/K plus occupation override pushbutton and occupation status display.

### Outputs

Auxiliary 24 Vac output	:(/230 only) 24 Vac, uses part of 400 mA
OUT1	:Fan On/off Relay Output. (/ <b>24VDC</b> normally open make only; / <b>230</b> changeover) relay contacts. Output rated at 5 A maximum at 240 Vac ( $\cos\phi >= 0.4$ ), and 24 Vdc (resistive load). Reduce to 2 A for 24 Vdc (inductive load). For USA/UL/24VAC, UL rating applies up to 30 V. Arc suppression circuit (RC) should be fitted for inductive loads, see TG200208. The fan is switched on when the relay is energised.
OUT2, 3, 4, 5	:Triac outputs equivalent to 24 Vac solid state relays. Use part of 400 mA supply shared between all four triac outputs (and 24 Vac auxiliary output for /230 version). The function of these outputs varies with the strategy running in the controller:
/AR2	
OUT2/OUT3	:Raise/Lower (floating point) outputs to heat cool damper
OUT4/OUT5	:unused triac outputs.
/WR2	
OUT2/OUT3	:Raise/Lower (floating point) outputs to drive heating or cooling valve.
OUT4/OUT5	:unused triac outputs
/WR4	
OUT2/OUT3	:Raise/Lower (floating point) outputs to drive heating valve.
OUT4/OUT5	:Raise/Lower (floating point) outputs to drive cooling valve.
/WT2	
OUT2	:Thermic output to drive heating or cooling valve.
OUT3/OUT4/OUT5	:unused triac outputs
/WT4	
OUT2	:Thermic output to drive heating valve.
OUT3	:unused triac output
OUT4	:Thermic output to drive cooling valve.
OUT5	:unused triac output
Version	:This document applies to the following version:
Firmware	:v5.1 or later
Strategy	:IQL11+ generic strategy release 9, /USA/UL/ release US01.

©Echelon, LON, Neuron, LONWORKS and LONMARK are trademarks of Echelon Corporation registered in the United States and other countries.

Please send any comments about this or any other Trend technical publication to [techpubs@trendcontrols.com](mailto:techpubs@trendcontrols.com)

© 2008 Honeywell Technologies Sàrl, ECC Division. All rights reserved. Manufactured for and on behalf of the Environmental and Combustion Controls Division of Honeywell Technologies Sàrl, Ecublens, Route du Bois 3, Switzerland by its Authorized Representative, Trend Control Systems Limited.

Trend Control Systems Limited reserves the right to revise this publication from time to time and make changes to the content hereof without obligation to notify any person of such revisions or changes.

### Trend Control Systems Limited

P.O. Box 34, Horsham, West Sussex, RH12 2YF, UK. Tel:+44 (0)1403 211888 Fax:+44 (0)1403 241608 [www.trend-controls.com](http://www.trend-controls.com)

### Trend Control Systems USA

6670 185th Avenue NE, Redmond, Washington 98052, USA. Tel: (425)897-3900, Fax: (425)869-8445 [www.trend-controls.com](http://www.trend-controls.com)