

IQ21x Series Controllers



Description

The IQ21x series of intelligent controllers are designed for use as unitary controllers in building control systems. Full compatibility with other Trend IQ controllers enables the IQ21x to integrate the local environmental needs with the bulk air conditioning system in order to optimise both comfort and running costs. The controllers have 5 inputs and 6 outputs. The IQ211 has 6 triac outputs, and the IQ212 has 4 triac outputs and two 0 to 10 V outputs.

Features

- Stand alone or integrated system operation
- 1 second cycle time and extended logging
- Small footprint
- 2 thermistor, 1 universal analogue, and two digital inputs
- 6 triac, or 4 triac and two 0 to 10 V outputs
- 5 time zones

Physical

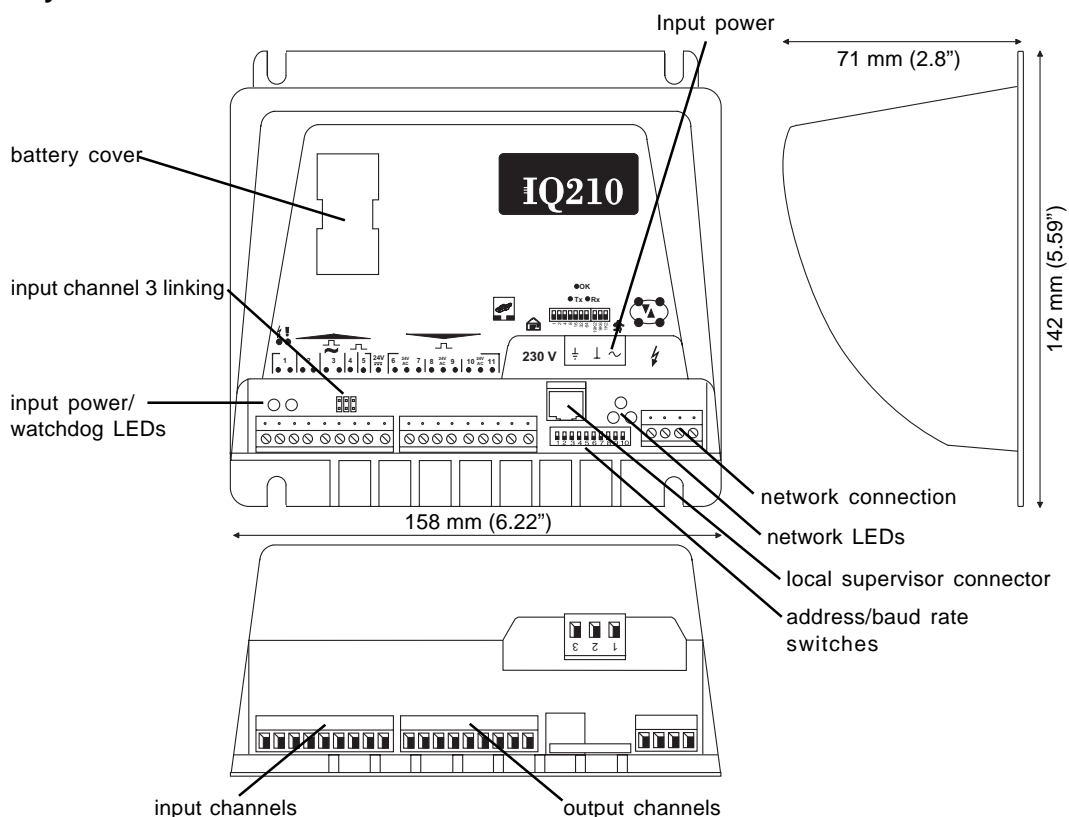

FUNCTIONALITY

The IQ Controller's functionality can be divided into three sections, the strategy, the firmware, and the hardware.

STRATEGY

The strategy processes inputs according to a set of instructions and then outputs signals which can be used to control equipment.

Configuration: The IQ21x uses the standard IQ configuration mode which enables configuration using the network, or direct connection. SET can be used to create a strategy data file (.IQ2) which can then be downloaded to the controller and subsequently uploaded for backup purposes if connected to the controller directly or using the network.

Modules: The strategy consists of a number of individual functional blocks known as configuration modules. These blocks can be linked in various combinations to enable equipment to be controlled in accordance with the building's requirements. The table lists the different types of configuration modules and the number of each type available with IQ21x.

Full details of the modules are given in the IQ Configuration Manual and Addendum. The IQ21x contains the normal IQ2 features as described in IQ Configuration Manual Addendum: Engineers Journal (J), I/O Summary (i/o) Loader Issue (R(c), 'c' lower case), Serial Number (R(s), 's' lower case), Supply Frequency Option, Enhanced Logging, Module position, and Strategy Cleardown.

Module Type	Number	Module Type	Number
Sensor	12	Critical Alarm	4
Sensor type	5	Alarm History	20
Loop	6	IC Comms	4
Function	40	Digital Inputs	12
Logic	40	Fast Sequence	8
Driver	8	Zone	5
Knob	10	Schedule	4
Switch	10	Calendar	20
Sensor log	10	User Password	6
Sequence step	100	Sequence time	1 s
Analogue Nodes	255	Digital Nodes	506
Display	60	Directory	10
Page	15	Route	50
Group	10	New Alarm Log	40
Destination	7		

FIRMWARE

Communications: When operating as part of a Building Management System, the IQ21x will be connected to other devices using the Trend Network. This means that information within the IQ21x can be accessed using one of the Trend supervisor programs, or passed to other Trend IQ controllers using inter-controller communications, enabling the sharing of information across the whole system.

HARDWARE

Unit: The IQ21x is supplied in a sealed plastic enclosure. It has a 4 point mounting to facilitate installation. There is no need to open the unit for normal use and maintenance. An optional metal enclosure with cable glanding knockouts (ENCLS/MBOX/IQ21x) is available.

Input power: 230 Vac or 24 Vac, 50/60 Hz. If one side of the 24 Vac input power is connected to earth (ground), ensure correct polarity.

Fusing: The controller has no replaceable fuses; protection is provided by means of self-resetting thermally protected transformer. The 24 Vac version has a solid state multifuse.

Auxiliary output supply: The IQ21x has a 24 Vdc auxiliary output supply for relay modules etc. with a maximum current availability of 50 mA. This is in addition to a full I/O complement, except if input channel 3 is linked for loop powered current input (IL), the available current is reduced to 30 mA.

Connectors: Two part connectors are used throughout to facilitate wiring - Cu only.

Indicators: LED indicators for receive and transmit network current flow (RX, TX) and Lan OK (OK), power, and watchdog. See specification section for details.

Network: The network terminals facilitate connection of 2 wire cables. The standard Trend node features are included (TX RX, and OK, indicators, bypass relay, and network alarm generation).

Address/Baud rate switch: The address on the Lan is set by poles 1 to 7 in range 1, 4 to 9, 11 to 119 and must be unique on the Lan. The baud rate is set by poles 8 to 10 in the range 1k2, 9k6, 19k2 and must match the other nodes on the Lan. The address/baud rate switch may also be used to perform a strategy cleardown; this is done by setting all the address/baud rate poles to zero before power up (see Installation Instructions, TG200059 and IQ Configuration Manual Addendum). For this reason the address should normally be set non-zero.

Battery Backup: Details about the strategy configuration, time and date, and logged data are stored in RAM. A plug-in lithium cell (accessible using a clip-on cover in the top of the unit) provides power to maintain the data in the event of power fail or the controller being switched off. The battery has a shelf life of at least 10 years.

HARDWARE (Continued)

I/O channels: The IQ21x is supplied in two versions, the IQ211 and IQ212, which have different I/O combinations, see below.

Variant	Thermistor Inputs	Universal Inputs	Digital only Inputs	Analogue Voltage Outputs	Digital (Triac) Outputs
IQ211	2	1	2	0	6
IQ212	2	1	2	2	4

Thermistor Inputs (input connections 1 and 2)

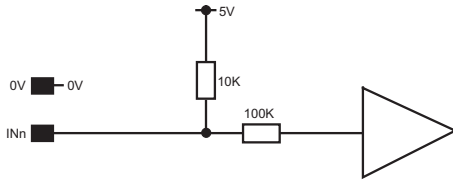

Digital Only Inputs (input connections 4 and 5)

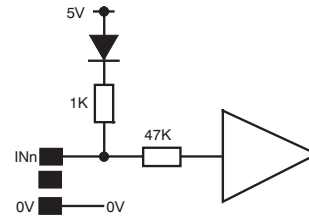

Universal Input (input connection 3)

Linkable for thermistor (T), digital (D), voltage (V), or current (I); the current input can be loop powered from the IQ (IL), or be externally supplied (Ix).

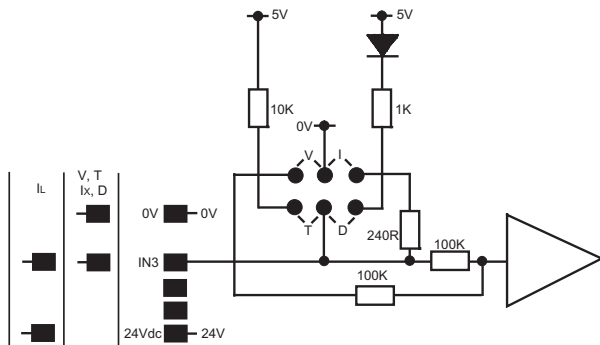

Analogue Voltage Outputs (output connections 6 and 7 - IQ212 only)

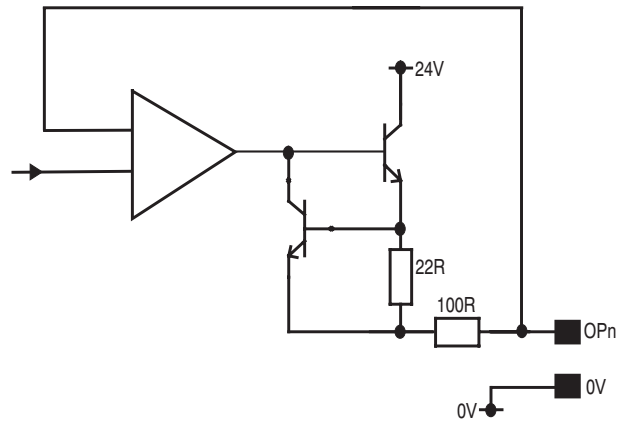

Digital (Triac) Outputs (output connections 6 to 11 - IQ211, output connections 8 to 11 - IQ212)

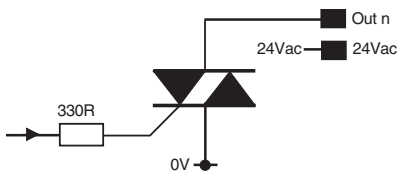

PC or Network Display Panel: A computer running a Trend Supervisor or Engineering Tool can be connected locally to the controller using its supervisor port. A Network Display Panel may be connected instead of a PC. When connected in this way the supervisor or NDP can communicate only to the controller.

A special adaptor cable (CABLE/EJ104029) enables the NDP's signal and power to be available from the local supervisor port connector (RJ11), this uses 75 mA of 24 V auxiliary output supply.

The adjacent diagram illustrates the alternative connection of a computer (local supervisor or engineering tool) or a Network Display Panel.

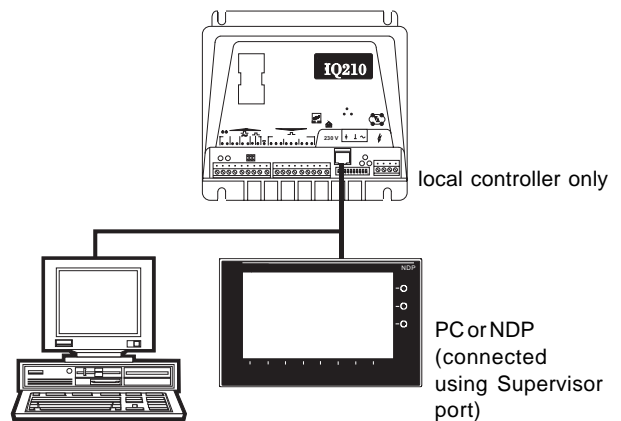

COMPATIBILITY

Supervisors:	94x series, 921, 96x, Viewpoint+, IQView.	Interface:	communications. It can be connected to Trend interface modules. Check interface module specification to ensure compatibility.
Utility software:	PowerTool, 822+/Toolbox version 6, 841 Strategy Browser, 842 Change Tracker, SET.	Local Display:	Network Display Panel (external), (local connection only).
Controllers:	It can communicate to other Trend IQ controllers using inter-controller		

The IQ Configuration Reference Manual Addendum covers the compatibility between different types of strategy files, and between the IQ21x sensor logs, and supervisors and software tools.

FIELD MAINTENANCE

The IQ Controller requires virtually no routine maintenance. The battery replacement is described in the IQ21x Installation Instructions (TG200059) - Replacing the Battery .

INSTALLATION

The IQ21x Controller is installed in a cabinet or panel, using 4 screws and washers. For IQ21x/USA, the unit is UL rated as 'UL916, listed open energy management equipment'. The procedure involves:

Mounting the controller in position	Disconnecting I/O, network
Connecting power, do not power up	Powering up
Connecting the network	Checking network
Terminating the I/O, leave unconnected	Configuring the strategy
Connecting the auxiliary output supply output, if used	Connecting inputs and test
Connecting any input or output interfaces	Connecting outputs and test
Specifying network address and baud rate	Backing up configuration
Performing input channel linking	

This installation procedure is covered by the IQ21x Installation Instructions (TG200059).

INSTALLATION (Continued)

CONNECTIONS

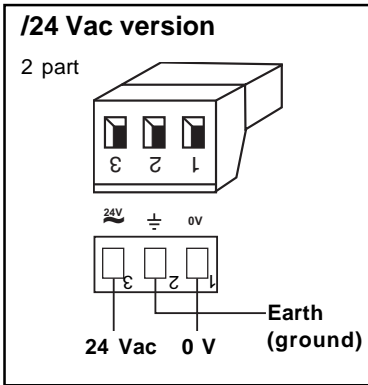
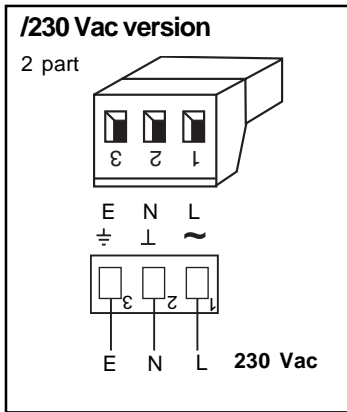

Inputs

2 part connectors with 9 screw terminals for 0.5 to 2.5 mm² cross section area (14 to 20 AWG) cable - Cu only.

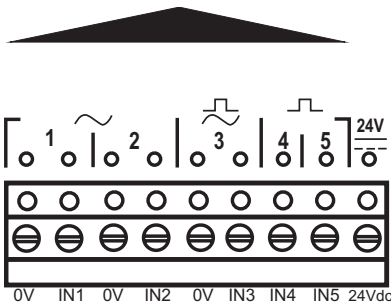

Voltage Outputs

2 part connectors with 9 screw terminals for 0.5 to 2.5 mm² cross section area (14 to 20 AWG) cable - Cu only.

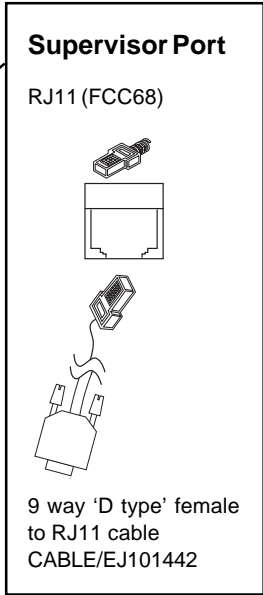
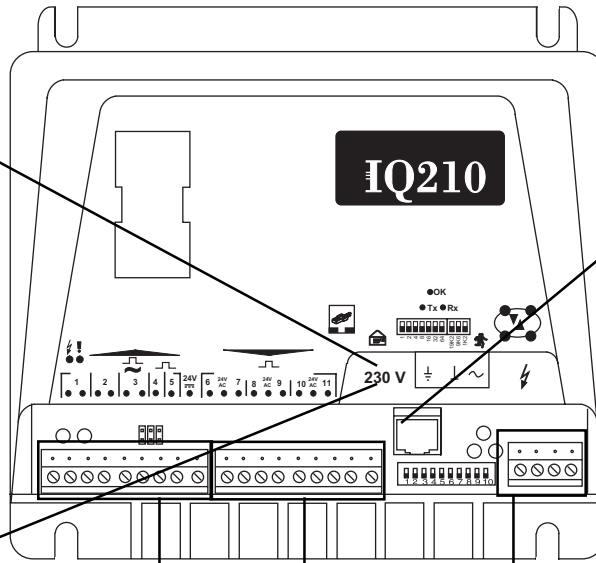
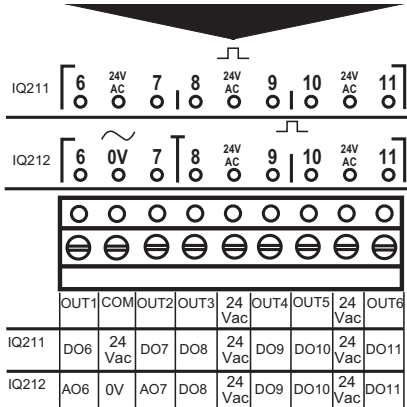

Network

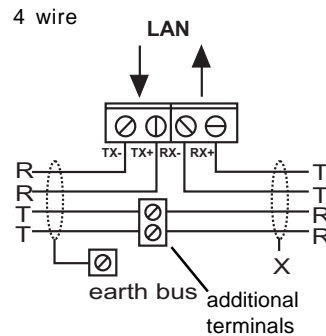
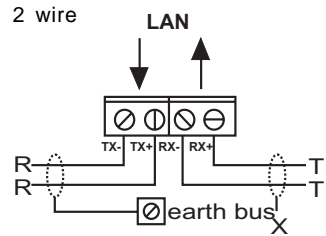

DISPOSAL

COSHH (Control of Substances Hazardous to Health - UK Government Regulations 2002) ASSESSMENT FOR DISPOSAL OF IQ22x Controllers. The only part affected is the lithium battery which must be disposed of in a controlled way.

RECYCLING. 

All plastic and metal parts are recyclable. The printed circuit board may be sent to any PCB recovery contractor to recover some of the components for any metals such as gold and silver.



WEEE Directive :

At the end of their useful life the packaging, product, and batteries should be disposed of by a suitable recycling centre.

Do not dispose of with normal household waste.

Do not burn.

ORDER CODES

Non USA Order Code	USA Order Code	
IQ211/230	not available in USA	IQ211 controller (2 Thermistor Inputs, 1 Universal Input, 2 Digital only Inputs, 6 Triac (digital) Outputs) for 230 Vac.
IQ211/24	not available in USA	IQ211 controller (2 Thermistor Inputs, 1 Universal Input, 2 Digital only Inputs, 6 Triac (digital) Outputs) for 24 Vac.
IQ212/230	not available in USA	IQ212 controller (2 Thermistor Inputs, 1 Universal Input, 2 Digital only Inputs, 2 Analogue Voltage Outputs, 4 Triac (digital) Outputs) for 230 Vac.
IQ212/24	not available in USA	IQ212 controller (2 Thermistor Inputs, 1 Universal Input, 2 Digital only Inputs, 2 Analogue Voltage Outputs, 4 Triac (digital) Outputs) for 24 Vac.
IQ211/UNB/USA/UL/24	882000230	UL rated IQ211 controller (2 Thermistor Inputs, 1 Universal Input, 2 Digital only Inputs, 6 Triac (digital) Outputs) for 24 Vac.
IQ212/UNB/USA/UL/24	882000240	UL rated IQ212 controller (2 Thermistor Inputs, 1 Universal Input, 2 Digital only Inputs, 2 Analogue Voltage Outputs, 4 Triac (digital) Outputs) for 24 Vac.

Accessories

Non USA Order Code	USA Order Code	
ENCLS	not available in USA	600 mm x 600 mm x 210 mm IP55 enclosure.
ENCLS/MBOX/IQ21x	not available in USA	180 mm x 280 mm x 80 mm IP30 enclosure for wall mounting IQ21x with glanding and internal DIN rail.
CABLE/EJ101442	not available in USA	Adaptor cable RJ11 to 9 way 'D type' Female for local PC connection.
CABLE/EJ104029	not available in USA	Adaptor cable RJ11 to 9 Way 'D type' Female and 2 screw terminals for NDP connection.

SPECIFICATIONS

Electrical

CPU	:68334 32 bit micro controller
CPU speed	:16.78 MHz
Cycle time	:1 s
Memory	:128 kbyte battery-backed SRAM, and 256 kbyte Flash.
Input power supply	
/230	:230 Vac +15 -10 %, 50 to 60 Hz
/24	:24 Vac ±10%, 50 to 60 Hz
Auxiliary output supply	:24 Vdc ±15%, 50 mA independent of configuration.
Consumption	:13 VA max
Fusing	:No replaceable fuses. All protection self-resetting.
Battery backup	:Battery maintains time, and logged data with input power off for at least 5 years.
Battery	:Saft LS3, 3.6 V, ½AA, 950 mAh or equivalent.
Clock accuracy	:30 s per month (typical).
Network transmission	:20 mA serial 2 wire current loop, opto-isolated, polarity independent receiver, balanced transmitter.
Supervisor transmission	:RS232, EIA/TIA/232E, V28.
Distance	
Supervisor	:15 m (16 yds).
Network	:Dependent on cable type, see table.

Cable	1k2 baud	9k6 baud	19k2 baud	No. of Wires
Belden 9182	1000 m (1090 yds)	1000 m (1090 yds)	700 m (765 yds)	2
Belden 9207	1000 m (1090 yds)	1000 m (1090 yds)	500 m (545 yds)	2
Trend TP/1/1/22/HF/200 (Belden 8761)	1000 m (1090 yds)	700 m (765 yds)	350 m (380 yds)	2
Trend TP/2/2/22/HF/200 (Belden 8723)	1000 m (1090 yds)	500 m (545 yds)	250 m (270 yds)	4

Baud rate	
Network	:Selectable by switch 1k2, 9k6, or 19k2 set to be same as other nodes on Lan.
Supervisor (or NDP)	:9k6.
Network addresses	
Controller	:Selectable by switch, 116 nodes addressable (1,4 to 119 excluding 10), set to be unique on Lan.
Inputs/Outputs	
IQ211	:2TI, 1UI, 2DI, 6DO
IQ212	:2TI, 1UI, 2DI, 2VO, 4DO

Key:

TI=Thermistor Input
 UI=Universal input
 DI=Digital only input
 VO=Analogue voltage output
 DO= Digital (triac) output

Signal Cable	:Analogue voltage, Analogue current, Thermistor, or Digital inputs, and Analogue voltage outputs. Trend TP/1/1/22/HF/200 recommended (Belden 8761)
Inputs	:2 thermistor (T) inputs, 1 universal input linkable for analogue voltage (V), analogue current (I), thermistor (T) or digital (D). 2 digital only (D) inputs.
Analogue voltage (V)	:12 bit resolution (4096 steps - effective). Minimum 60 dB series mode rejection at input power frequency 0 to 10V, input resistance 200 kW, accuracy 50 mV equivalent to ±0.5% of span.
Analogue current (I)	:12 bit resolution (4096 steps - effective). Minimum 60 dB series mode rejection at input power frequency 0 to 20 mA, input resistance 240 W, accuracy 0.5% of span (i.e. 100 mA).

Thermistor (T)	:12 bit resolution (4096 steps - effective). Minimum 60 dB series mode rejection at input power frequency. Thermistor bridge resistor 10 kW 0.1%, accuracy 0.5% of span. Bridge supply 5V.
Digital (D)	:Volt free contact. Wetting current 4 mA. Count rate 30 Hz
Outputs	
Analogue Voltage	:11 bit resolution (2048 steps). 0 to 10 V with 20 mA current limit, accuracy ±0.5% of span.
Triac Output	:Equivalent to 24 Vac solid state relay. 230 Vac version: Total of 300 mA available. 24 Vac version: Total of 500 mA available.
Indicators	
Power	:(green) ON when input power is connected.
Watchdog	:(red) ON if controller has a software fault.
OK	:(green) ON if network is operating. Flashes if prohibited controller network address set (0, 2, 3, >119).
RX	:(yellow) ON if current is entering the network receiver.
TX	:(yellow) ON if current is flowing from network transmitter.

Note that the watchdog LED flashes momentarily on power up.

Mechanical

Dimensions	:158 mm (6.22") x 142 mm (5.59") x 71 mm (2.8").
Box material	:ABS
Protection	:IP30
Weight	
/230	:725 g (1lb 9.6 ozs)
/24	:335 g (11.8 ozs)
Connectors	
Input power	:2 part connector for 0.5 to 2.5 mm ² cross section area (14 to 20 AWG) cable.
Network	:2 part connector with 4 screw terminals for 0.5 to 2.5 mm ² cross section area (14 to 20 AWG) cable.
I/O	:2 part connector with 9 screw terminals for 0.5 to 2.5 mm ² cross section area (14 to 20 AWG) cable - Cu only.
Supervisor	:RJ11 (FCC68), for Trend utility software connected using adaptor cable CABLE/EJ101442. Supplies signal and power to NDP using CABLE/EJ104209.

Environmental

EMC

Emissions :EN50081-1.

Immunity :EN50082-2.

Safety :EN61010.

UL (IQ21x/USA only) :The unit is UL rated as 'UL916, listed open energy management equipment'.

Ambient limits

storage :-10 °C (14 °F) to 50 °C (122 °F)

operating :0 °C (32 °F) to 45 °C (113 °F)

humidity :0 to 90 %RH non-condensing

Version

This document covers

Firmware :V3 or greater

Board :AM103614

Manufactured for and on behalf of the Environmental and Combustion Controls Division of Honeywell Technologies Sàrl, Ecublens, Route du Bois 37, Switzerland by its Authorized Representative, Trend Control Systems Limited.

Trend Control Systems Limited reserves the right to revise this publication from time to time and make changes to the content hereof without obligation to notify any person of such revisions or changes.

Trend Control Systems Limited

P.O. Box 34, Horsham, West Sussex, RH12 2YF, UK. Tel:+44 (0)1403 211888 Fax:+44 (0)1403 241608 www.trend-controls.com

Trend Control Systems USA

6670 185th Avenue NE, Redmond, Washington 98052, USA. Tel: (425)897-3900, Fax: (425)869-8445 www.trend-controls.com
