

IQ22x Series Controllers



Description

Medium size controller with extremely versatile I/O capability suitable for a broad range of applications, especially in the area of dedicated controls (e.g. air handling units, terminal units, chillers). Various I/O configurations available, ranging from 8 points to 20 points. Options of integral or external 2-line display panel.

Features

- 1 second cycle time and extended logging
- configurable, flexible, inputs and outputs
- small footprint
- 7 universal inputs and 1 digital-only input maximum
- 7 analogue and 5 SPCO relay outputs maximum
- integral or external 2-line display panel options
- 3 point mounting

Physical

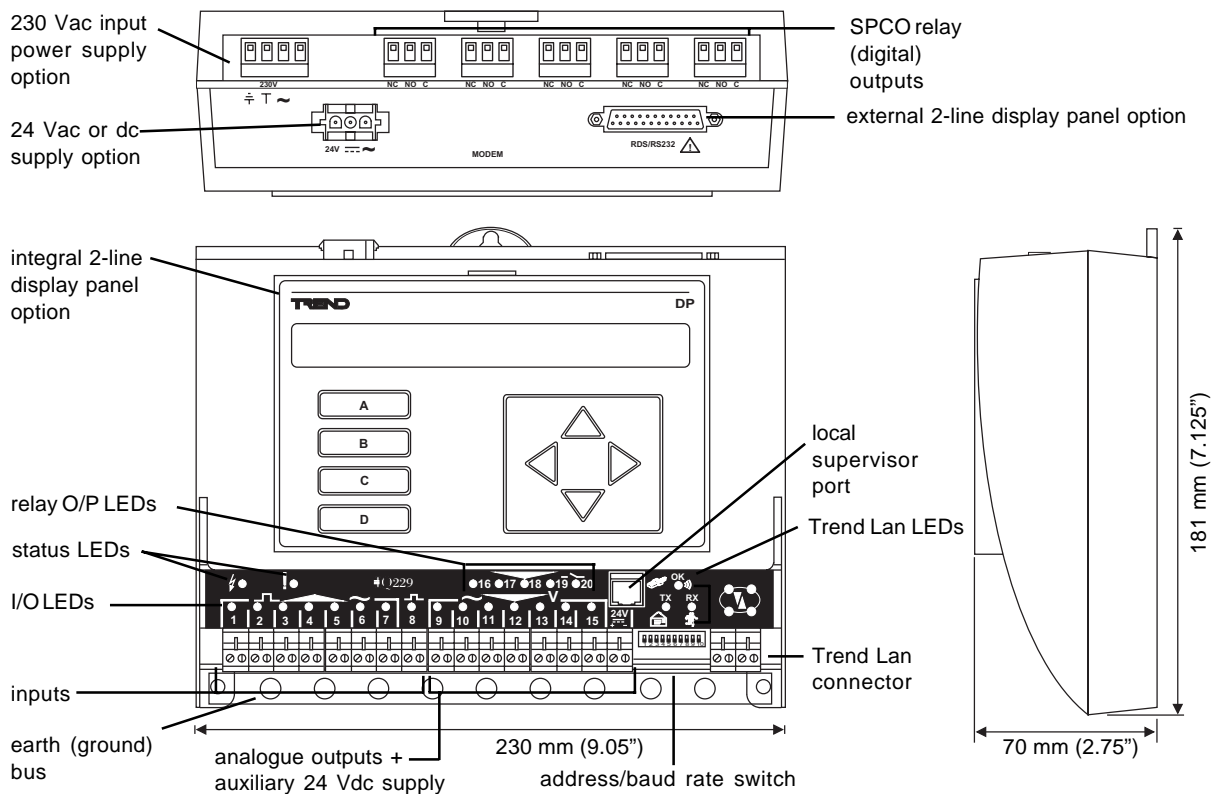

FUNCTIONALITY

The IQ Controller's functionality can be divided into three sections, strategy, firmware, and hardware.

STRATEGY

The strategy processes inputs according to a set of instructions and then outputs signals which can be used to control HVAC equipment.

Configuration: The IQ22x uses the standard IQ configuration mode which enables configuration across the network, or by way of the supervisor port. SET can be used to create a strategy data file (.IQ2) which can then be downloaded to the controller and subsequently uploaded for backup purposes if connected to the controller directly or across the network.

Modules: The strategy consists of a number of individual functional blocks known as configuration modules. These blocks can be linked in various combinations to enable HVAC equipment to be controlled in accordance with the building's requirements. The table lists the different types of configuration modules and the number of each type available with IQ22x.

Module Type	Number	Module Type	Number
Sensor	32	Critical Alarm	4
Sensor type	8	Alarm History	20
Loop	16	IC Comms	16
Function	90	Digital Inputs	32
Logic	90	Fast Sequence	8
Driver	12	Zone	5
Knob	30	Schedule	8
Switch	20	Calendar	20
Sensor log	20	User Password	6
Sequence step	240	Sequence time	1 s
Analogue Nodes	255	Digital Nodes	505
Display	140	Directory	25
Group	10	Route	50
Destination	7	New Alarm Log	100

Full details of the modules are given in the IQ Configuration Manual and Addendum. The IQ22x contains the normal IQ2 features as described in IQ Configuration Manual Addendum: Engineers Journal (J), I/O Summary (i/o) Loader Issue (R(c),'c' lower case), Serial Number (R(s), 's' lower case), Supply Frequency Option, Enhanced Logging, Module position, and Strategy Cleardown.

I/O Channels: Care should be taken to distinguish between configuration channel numbers used in configuration mode and printed on the board (input channels 1 to 8, output channels 1 to 12) and external connection numbers show on the label (numbered sequentially, inputs 1 to 8, and outputs 9 to 20). Once the configuration channel is selected in configuration mode, the external connection is displayed alongside.

The variable configuration of the IQ22x can result in a gap in the output channel sequence. Thus IQ221 will result in external connections 9 and 10 (voltage) and 16 to 20 (relay) with a gap from 11 to 15.

FIRMWARE

Communications: When operating as part of a Building Management System, the IQ22x will be connected to other devices by the Trend Network. This means that information within the IQ22x can be accessed using one of the Trend supervisor programs, or passed to other Trend IQ controllers using inter-controller communications, enabling the sharing of information across the whole system.

When connected to the network the controller can use up to 2 different addresses. One address is for the controller itself (set by front panel switch), the second is optional, and is for the supervisor port (locally connected supervisor or display). The controller's address is set by a switch, and the supervisor port address is set up in the strategy configuration (address module).



HARDWARE

Unit: The IQ22x is supplied in a plastic enclosure with a transparent plastic flip-up terminal cover. It has a 3 point mounting to facilitate installation. An optional metal enclosure with cable glanding knockouts (ENCLS/MBOX/IQ22x) is available.

Connectors: Two part connectors are used throughout to facilitate wiring. A busbar is provided for screen termination.

Power: 230 Vac 50/60 Hz, 24 Vac or 24 Vdc.

Fusing: The controller has no replaceable fuses; protection is provided by means of a self-resetting thermally protected transformer. The 24 V ac or dc version has a solid state multifuse.

Indicators: LED indicators for receive and transmit network current flow (RX, TX) and network OK (), also for all I/O channels, power (), and watchdog (). See specification section for details.

Network: The network terminals facilitate connection of 2 wire cables. The standard Trend node features are included (TX RX, and network OK, ), indicators, bypass relay, and network alarm generation). There is also the facility for connection of a supervisor or network display panel to the network through the controller without the need for additional node controllers.

Address/Baud rate switch: The address on the Lan is set by poles 1 to 7 in range 1, 4 to 9, 11 to 119 and must be unique on the Lan. The baud rate is set by poles 8 to 10 in the range 1k2, 9k6, 19k2 and must match the other nodes on the Lan. The address/baud rate switch may also be used to perform a strategy cleardown; this is done by setting all the address/baud rate poles to zero before power up (see Installation Instructions, TG200001 sheet 3 and IQ Configuration Manual Addendum). For this reason the address should normally be set non-zero.

Battery Backup: Details about the strategy configuration, time and date, and logged data are stored in RAM. A plug-in lithium cell provides power to maintain the data in the event of power failure, or the controller being switched off.

HARDWARE (continued)

Auxiliary Supply: The IQ22x has a 24 Vdc auxiliary supply for relay modules etc.

24 V(ac or dc) Versions: At least 100 mA is available independent of I/O usage and of 2DP/RDS or display being connected.

230 Vac input power supply Versions: Typically a maximum of 150 mA is available but this may be reduced by I/O usage and connection of 2DP or RDS. There is 350 mA available to be shared by 2DP/RDS, display, I/O, and AUX. The AUX (auxiliary supply) is current limited to 150 mA typical (100 mA minimum).

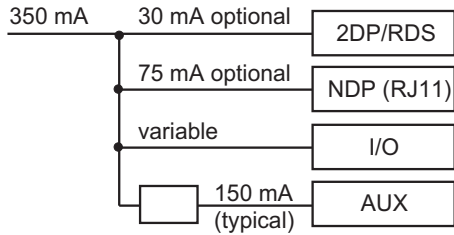

If a 2DP or RDS is connected it will consume 30 mA.
If an NDP is connected it will consume 75 mA.

The I/O consumptions are as follows:

Current input (loop powered)	20 mA per input
All other inputs	0 mA
Voltage output	3 mA plus loading per output (23 mA per output max)
Relay output	12 mA per output

The remaining current is available from the AUX supply but it cannot exceed 150 mA (typically 150 mA but at least 100 mA).

e.g. If an IQ229/230 has RDS fitted, and has 4 loop powered current inputs, 2 voltage inputs, 5 voltage outputs consuming 10 mA each, and 5 relay outputs, what is the available current from the AUX supply?

RDS consumption	= 30 mA
I/O usage is:	
4 current inputs @ 20	= 80 mA
2 voltage inputs @ 0	= 0 mA
5 voltage outputs @ 13 (10 + 3)	= 65 mA
5 relay outputs @ 12	= 60 mA
Total usage	= 235 mA
Current available to AUX is 350 - 235	= 115 mA

Thus current available to AUX is between 100 to 115 mA.

I/O channels: The IQ22x is supplied with a minimum of 8 I/O channels and a maximum of 20 I/O channels. There is a range of configuration versions (see Order Code section). Note that available I/O may be reduced due to auxiliary supply use or by fitting 2DP or RDS (see Auxiliary Supply section above).

Universal Inputs

(external connections 1 to 7, configuration channels IN1 to IN7) - linkable for thermistor (T), digital (D), voltage (V), or current (I); the current input can be loop powered from the IQ (IL), or be externally supplied (Ix).

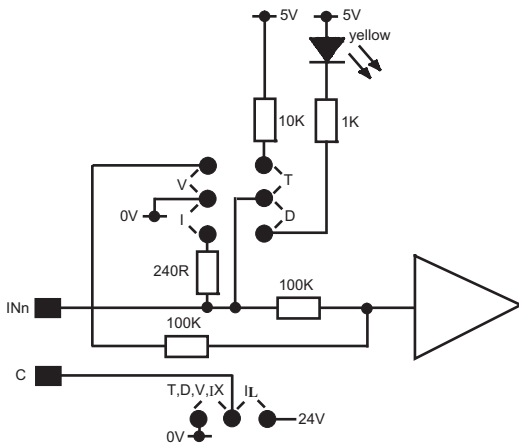

Note:

- Ix: Externally powered current input
- IL: Loop powered current input

For loop powered current sensor, link as described above (IL) but connect between INn and the 24 Vdc auxiliary terminal (+).

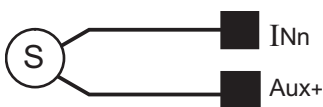

Analogue Voltage Outputs

(external connections 9 to 15, configuration channels, OP1 to OP7)

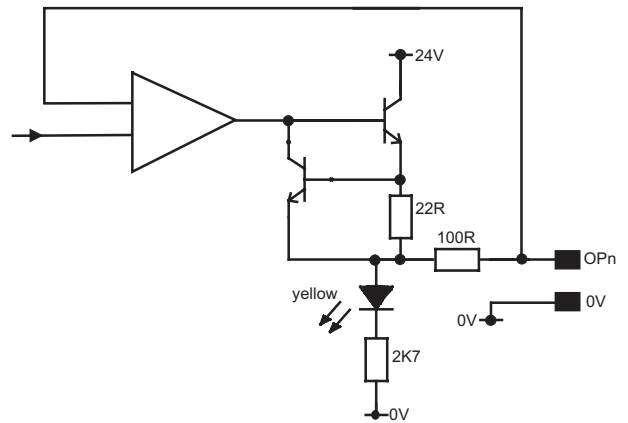

HARDWARE (continued)

Digital only Input

(external connection 8, configuration channel IN8)

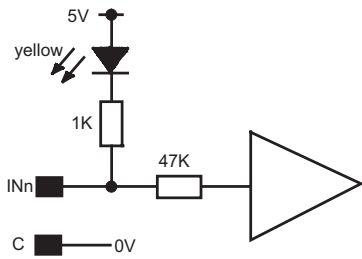

Digital (Relay) Outputs

(external connections 16 to 20, configuration channels OP8 to OP12)

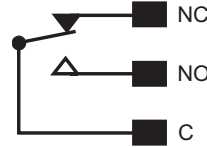

Displays: The IQ22x can have several types of local display; 2-line Display Panel, PC, IQView, SDU or RD.

2-line Display Panel: The controller may be purchased with a 2DP option fitted in the cover or there is a retrofit kit comprising a replacement cover with integral 2DP (COVER/DP/IQ22x). Alternatively an external 2DP (i.e. HDP, FPK, ENCLS/FP) may be connected by fitting the KIT/2xx/RDS option which provides a 2 way D type female connector on the upper face of the unit. If a display panel is mounted in the front cover, it will not be possible to connect an external 2-line display. The 2DP provides access to parameters within the controller. Note that fitting a 2DP will reduce available 24 V current by 30 mA which may limit the I/O available, or auxiliary supply current (see Auxiliary Supply section).

PC or Other display : A computer running a Trend Supervisor or Engineering Tool can be connected to the Trend network using the controller's supervisor port without the need for an additional node controller although it does take a separate network address. When connected in this way the supervisor will have access to all devices on the network, and will function as if it were connected through its own node controller. An IQView (network display panel) may be connected instead of a PC.

The RD-IQ (Room Display) or SDU-IQ (Smart Display Unit) may also be connected. Only one device at a time may be connected to the controller's supervisor port.

The RD-IQ is a temperature sensor and 3 digit display with control and indication of setpoint, and optional control and indication of fan speed and occupancy. The SDU-IQ is a 4 line by 20 character display panel which enables the user to view and adjust selected controller parameters within the controller. It provides all the facilities necessary for the operation of a stand-alone building control system.

The diagrams below illustrate the various combinations in which the display panels and supervisor/engineering tools can be connected.

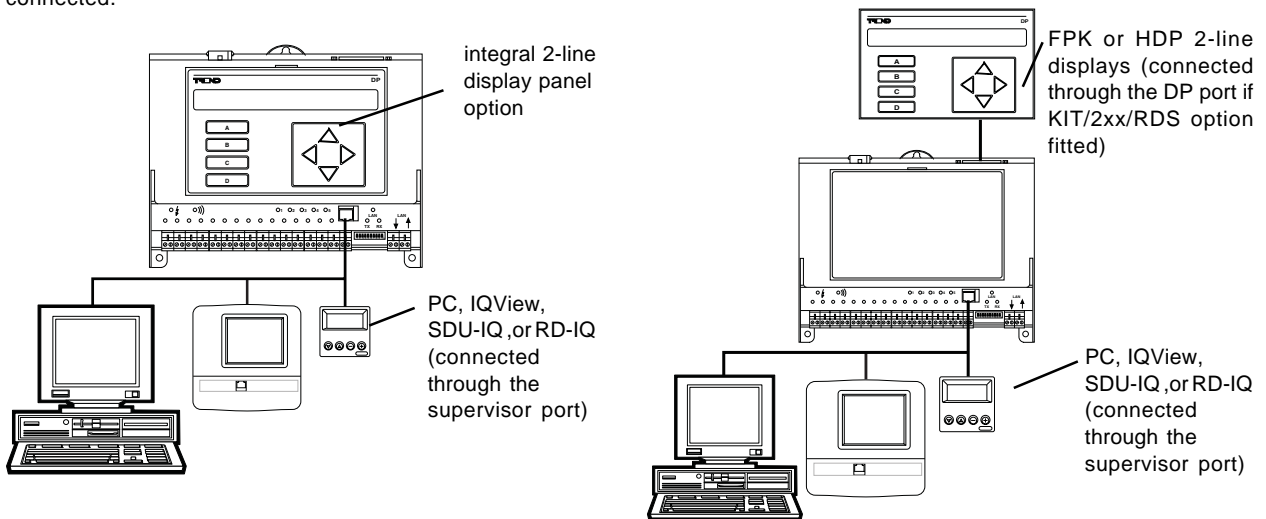

COMPATIBILITY

- Supervisors:** 963, 94x series, 916, 921, 962, Viewpoint+.
- Utility software:** SET, PowerTool, WupDn, 822+/Toolbox version 6,
- Controllers:** It can communicate to other Trend IQ controllers using inter-controller communications.
- Interface:** It can be connected to Trend interface modules. Check interface module specification to ensure compatibility.
- Local Display:** IQView, SDU-IQ, RD-IQ, NDP (external), 2-line Display Panel (external or internal).

The IQ Configuration Reference Manual Addendum covers the compatibility between different types of strategy files, and between the IQ22x sensor logs, and supervisors and software tools.

INSTALLATION

CONNECTIONS

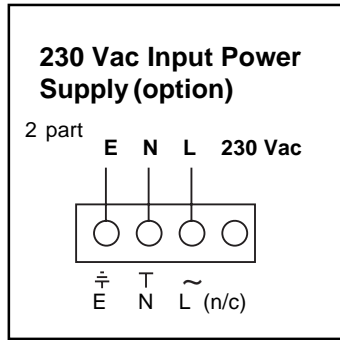

/RDS(option)
25 Way 'D' type female connector.
Connect 2-line Display Panel using cable supplied with it

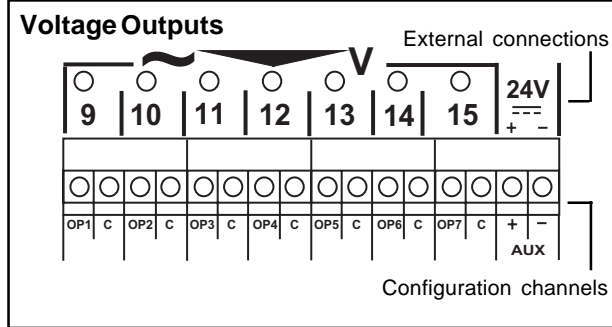
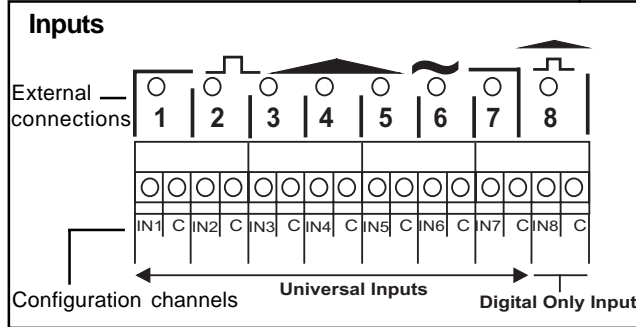
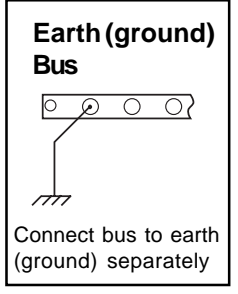
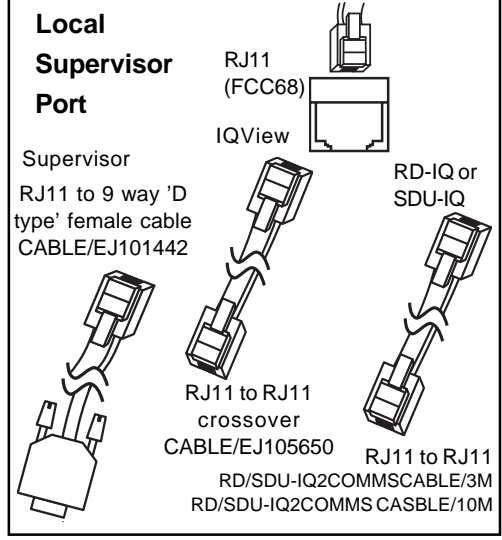
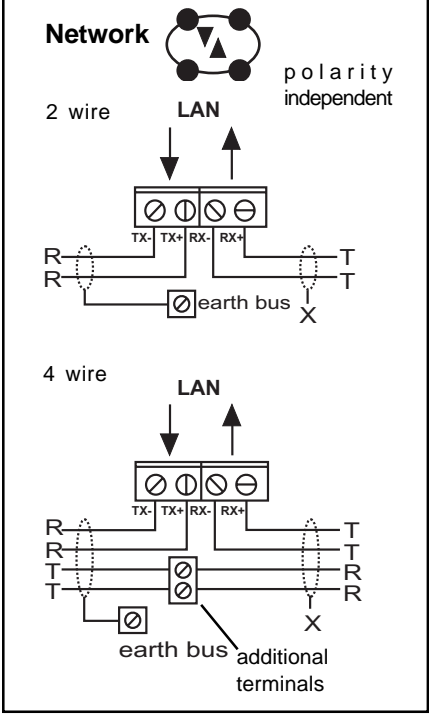
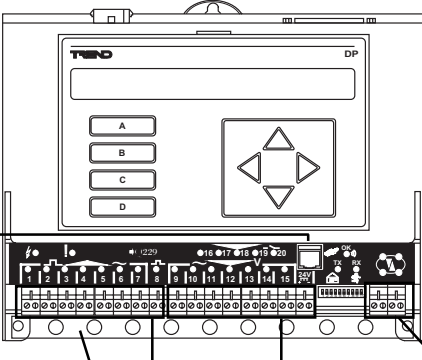
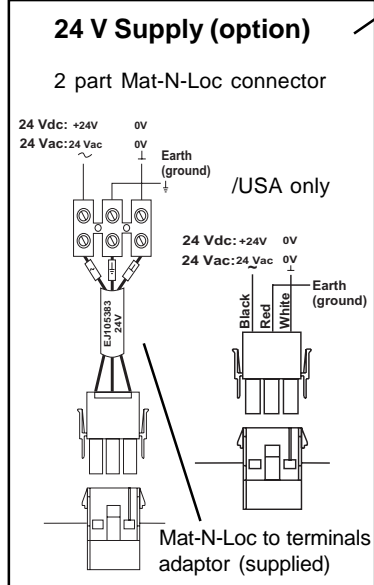
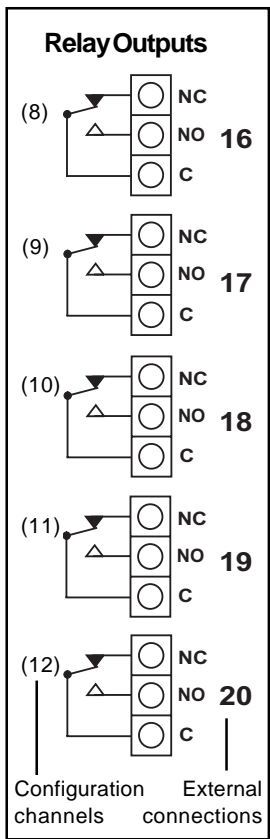
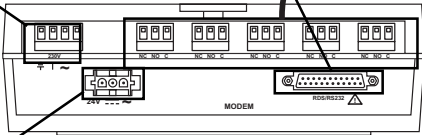

INSTALLATION (Continued)

The IQ22x Controller is installed on a flat surface, a wall, or panel, using 3 screws and washers. For IQ22x/USA only, the unit is UL rated as 'UL916, listed open energy management equipment'. The procedure involves:

- mount the controller in position
- connect power, do not power up
- connect the network
- terminate the I/O, leave unconnected
- connect the auxiliary supply output, if used
- connect any input or output interfaces
- specify network address and baud rate
- perform input channel linking
- disconnect I/O, network
- power up
- check network
- configure the strategy
- check operation
- connect outputs
- backup configuration

This installation procedure, is covered by the IQ22x Installation Instructions, TG200001, (Mounting, Configuration, and Options sheets). Sheet 3, Options, covers fitting an external 2-line display panel (if KIT/2xx/RDS is already fitted), connecting an external NDP or local PC, and mounting an IQ22x in an enclosure(ENCLS/). The installation in an MBOX is covered by ENCLS/MBOX/IQ22x installation instructions, TG200204.

FIELD MAINTENANCE

The IQ Controller requires virtually no routine maintenance, however it is recommended that the lithium battery be replaced every 5 years, as explained in the IQ22x Installation Instructions, TG200001, Sheet 3, Options.

DISPOSAL

COSHH (Control of Substances Hazardous to Health - UK Government Regulations 2002) ASSESSMENT FOR DISPOSAL OF IQ CONTROLLER. The only part affected is the lithium battery which must be disposed of in a controlled way.

RECYCLING.  All plastic and metal parts are recyclable. The printed circuit board may be sent to any PCB recovery contractor to recover some of the components for any metals such as gold and silver.



WEEE Directive :

At the end of their useful life the packaging, product, and battery should be disposed of via a suitable recycling centre.

Do not dispose of with normal household waste.
Do not burn.

ORDER CODES

		USA order code	
IQ221/230			6 Universal Inputs, 2 Analogue Voltage Outputs, 5 Relay Outputs, 230 Vac input power
IQ221/24	882000120		6 Universal Inputs, 2 Analogue Voltage Outputs, 5 Relay Outputs, 24 Vac/dc input power
IQ221/DP/230			6 Universal Inputs, 2 Analogue Voltage Outputs, 5 Relay Outputs, 230 Vac input power and display panel
IQ221/DP/24	882000130		6 Universal Inputs, 2 Analogue Voltage Outputs, 5 Relay Outputs, 24 Vac/dc input power and display panel
IQ222/230			6 Universal Inputs, 6 Analogue Voltage Outputs, 230 Vac input power
IQ222/24	882000140		6 Universal Inputs, 6 Analogue Voltage Outputs, 24 Vac/dc input power
IQ222/DP/230			6 Universal Inputs, 6 Analogue Voltage Outputs, 230 Vac input power, and display panel
IQ222/DP/24	882000150		6 Universal Inputs, 6 Analogue Voltage Outputs, 24 Vac/dc input power, and display panel
IQ223/230			7 Universal Inputs, 1 Digital Input, 7 Analogue Voltage Outputs, 1 Relay Output, 230 Vac input power
IQ223/24	882000160		7 Universal Inputs, 1 Digital Input, 7 Analogue Voltage Outputs, 1 Relay Output, 24 Vac/dc input power
IQ223/DP/230			7 Universal Inputs, 1 Digital Input, 7 Analogue Voltage Outputs, 1 Relay Output, 230 Vac input power, and display panel
IQ223/DP/24	882000170		7 Universal Inputs, 1 Digital Input, 7 Analogue Voltage Outputs, 1 Relay Output, 24 Vac/dc input power, and display panel
IQ228/230			7 Universal Inputs, 1 Digital Input, no outputs, 230 Vac input power
IQ228/24	882000180		7 Universal Inputs, 1 Digital Input, no outputs, 24 Vac/dc input power
IQ228/DP/230			7 Universal Inputs, 1 Digital Input, no outputs, 230 Vac input power, and display panel
IQ228/DP/24	882000190		7 Universal Inputs, 1 Digital Input, no outputs, 24 Vac/dc input power, and display panel
IQ229/230			7 Universal Inputs, 1 Digital Input, 7 Analogue Voltage Outputs, 5 Relay Outputs, 230 Vac input power
IQ229/24	882000200		7 Universal Inputs, 1 Digital Input, 7 Analogue Voltage Outputs, 5 Relay Outputs, 24 Vac/dc input power
IQ229/DP/230			7 Universal Inputs, 1 Digital Input, 7 Analogue Voltage Outputs, 5 Relay Outputs, 230 Vac input power, and display panel
IQ229/DP/24	882000210		7 Universal Inputs, 1 Digital Input, 7 Analogue Voltage Outputs, 5 Relay Outputs, 24 Vac/dc input power, and display panel

All units include an earth (ground) bus bar

KIT/2xx/RDS	882000220	Kit to enable connection of FPK or HDP 2-line display panels.
COVER/DP/IQ22x		Retrofit cover with integral 2-line display panel.
ENCLS/MBOX/IQ22x		261 mm (10.28") x 285 mm (11.22") x 77 mm (3.03") IP30 enclosure for wall mounting IQ22x with glanding and apertures for 2DP and LEDs, and integral busbar.
ENCLS		600 mm (23.6") x 600 mm (23.6") x 210 mm (8.26") IP55 enclosure.
ENCLS/FP		600 mm (23.6") x 600 mm (23.6") x 210 mm (8.26") IP55 enclosure fitted with 2-line display panel plus 2DP connection cable.
ENCLS/NDP		600 mm (23.6") x 600 mm (23.6") x 210 mm (8.26") IP55 enclosure with NDP on door plus connection cable.
CABLE/EJ101442		Adaptor cable RJ11 to 9 Way 'D type' Female for local PC connection.
CABLE/EJ104029		Adaptor cable RJ11 to 9 Way 'D type' Female and 2 screw terminals for NDP connection.

SPECIFICATIONS

Electrical

CPU	:68334 32 bit micro-controller
CPU speed	:16.78 MHz
Cycle time	:1 s
Memory	:128 kbyte battery backed SRAM, and 256 kbyte Flash.
Input power voltage	
/230	:230 Vac +15 % -10%, 50 to 60 Hz
/24	:24 Vac ±10%, 50 to 60 Hz or 24 Vdc (24 V to 36 Vdc)
Auxiliary supply	:24 Vdc ±10%, 150mA maximum (typical) dependent on configuration - see Auxiliary Supply section for details
Consumption	:13 VA max
Fusing	:No replaceable fuses required. All protection self-resetting.
Battery backup	:Battery maintains time, and logged data with input power off for at least 5 years.
Battery	:Saft LM2450, 3 V, or equivalent
Clock accuracy	:30 s per month (typical).
2-line display panel	:Optional 2x40 character display, with 4 programmable softkeys. Can be mounted in front cover, or externally using adaptor kit.
Network transmission	:20 mA serial 2 wire current loop, opto-isolated, polarity independent receiver, balanced transmitter.
Supervisor transmission	:RS232, EIA/TIA/232E, V28

Distance	
Supervisor	:15 m (17 yds)
Network	:Dependent on cable type, see table below:

Cable	1k2 baud	9k6 baud	19k2 baud	No. of Wires
Belden 9182	1000 m (1090 yds)	1000 m (1090 yds)	700 m (765 yds)	2
Belden 9207	1000 m (1090 yds)	1000 m (1090 yds)	500 m (545 yds)	2
Trend TP/1/1/22/HF/200 (Belden 8761)	1000 m (1090 yds)	700 m (765 yds)	350 m (380 yds)	2
Trend TP/2/2/22/HF/200 (Belden 8723)	1000 m (1090 yds)	500 m (545 yds)	250 m (270 yds)	4

Baud rate	
Network	:Selectable by switch 1k2, 9k6, or 19k2 set to be same as other nodes on Lan.
Supervisor (or NDP)	:9k6.
Network addresses	
Controller	:Selectable by switch, 116 nodes addressable (1,4 to 119 excluding 10) set to be unique on Lan.
Supervisor port	:Software selectable, 116 nodes addressable (1,4 to 119 excluding 10) set to be unique on Lan.

SPECIFICATIONS (Continued)**IQ22x Range**

IQ221	:6UI, 2VO, 5DO
IQ222	:6UI, 6VO
IQ223	:7UI, 1DI, 7VO, 1DO
IQ228	:7UI, 1DI
IQ229	:7UI, 1DI, 7VO, 5DO

Key

UI	:Universal input
DI	:Digital only input
VO	:Analogue voltage output
DO	:Digital (relay) output

Signal Cable :Analogue voltage, Analogue current, Thermistor, or Digital inputs, and Analogue voltage outputs. Trend TP/1/1/22/HF/500 recommended (Belden 8761)

Inputs :External connections 1 to 7, configuration channels IN1 to IN7, universal inputs (7 maximum) linkable for analogue voltage (V), analogue current (I), thermistor (T) or digital (D). External connection 8, configuration channel IN8, 1 digital only (D) input.

Analogue voltage (V) :12 bit resolution (4096 steps - effective). Minimum 60 dB series mode rejection at input power supply frequency. 0 to 10V, input resistance 200 kW, accuracy 50 mV equivalent to $\pm 0.5\%$ of span.

Analogue current (I) :12 bit resolution (4096 steps - effective). Minimum 60 dB series mode rejection at input power supply frequency. 0 to 20 mA, input resistance 240W, accuracy 0.5% of span (i.e. 100 μ A). Loop powered input supply is 20 to 36 Vdc.

Thermistor (T) :12 bit resolution (4096 steps - effective). Minimum 60 dB series mode rejection at input power supply frequency. Thermistor bridge resistor 10 kW 0.1%, accuracy 0.5% of span. Bridge supply 5V.

Digital (D) :voltage free contact
Count rate 30 Hz. Wetting current = 3 mA nominal. 5 V supply.
Status LED per channel (ON = closed contact).

Electrical**Outputs**

Analogue voltage :External connections, 9 to 15, Configuration channels OP1 to OP7 (7 maximum). 11 bit resolution (2048 steps). 0 to 10 V with 20 mA current limit, accuracy $\pm 0.5\%$ of span. Status LED per channel, light intensity increases with output voltage.

Relay output :External connections 16 to 20, Configuration channels OP8 to OP12 (5 maximum). 1 pole changeover relays, Outputs rated for 240 Vac single phase only 8A (resistive load), 5A (inductive, $\cos\phi=0.4$), 30 Vdc at 5A (resistive load), and 20 Vdc at 5A (inductive load). For 24 Vdc (inductive load) reduce to 2A. Arc suppression recommended, see Relay Output Arc suppression Installation Instructions, TG200208). Status LED per channel (ON = relay energised). For IQ22x/USA the UL rating applies to load of up to 30V.

Indicators

Inputs	:(yellow) Indicates status, only for digital inputs (ON = contact closed)
Analogue outputs	:(yellow) Light intensity increases with output voltage
Relay outputs	:(yellow) ON if relay energised
⚡ (power)	:(green) ON when input power supply is connected
! (watchdog)	:(red) ON if controller has a software fault
OK \rightarrow (network)	:(green) ON if network is operating. Flashes if prohibited controller network address set (0, 2, 3, >119).
RX	:(yellow) ON if current is entering the network receiver
TX	:(yellow) ON if current is flowing from network transmitter

Note that the ! (watchdog) LED flashes momentarily on power up

Mechanical

Dimensions :230 mm (9.05") x 181 mm (7.125") x 70 mm (2.78")

Material

Box	:ABS
Terminal cover	:Clear Styrolux
Protection	:IP30, NEMA 2
Weight	:1.4 kg (3 lb 2 ozs) including display, 100 gm (14 ozs)

Connectors

/230	:2 part connector for 0.5 to 2.5 mm ² cross section area (14 to 20 AWG) cable
/24...	:Mat-N-Loc 2 part connector
Network	:2 part connector with 4 screw terminals for 0.5 to 2.5 mm ² cross section area (14 to 20 AWG) cable.
I/O	:2 part connector with 2 screw terminals for 0.5 to 2.5 mm ² cross section area (14 to 20 AWG) cable.
Supervisor port	:RJ11 (FCC68), for Trend utility software connected using adaptor cable CABLE/EJ101442.
Display panel	25 way D type Female (if adaptor kit fitted).

Environmental**EMC**

Emissions	:EN50081-1.
Immunity	:EN50082-2.
Safety	:EN61010.
UL	:(IQ22x/USA only) The unit is UL rated as 'UL916, listed open energy management equipment'.

Ambient limits

storage	:-10 °C (14 °F) to 50 °C (122 °F)
operating	:0 °C (32 °F) to 45 °C (113 °F)
humidity	:0 to 90 %RH non-condensing

Flammability

Casing material :Flame retardance, UL99V0
Glow wire test, UL746A(3)

Version

This document covers:

Firmware	:v3 or greater
Board	:AM103995 v1

Manufactured for and on behalf of the Environmental and Combustion Controls Division of Honeywell Technologies Sàrl, Ecublens, Route du Bois 37, Switzerland by its Authorized Representative, Trend Control Systems Limited.

Trend Control Systems Limited reserves the right to revise this publication from time to time and make changes to the content hereof without obligation to notify any person of such revisions or changes.

Trend Control Systems Limited

P.O. Box 34, Horsham, West Sussex, RH12 2YF, UK. Tel:+44 (0)1403 211888 Fax:+44 (0)1403 241608 www.trend-controls.com

Trend Control Systems USA

6670 185th Avenue NE, Redmond, Washington 98052, USA. Tel: (425)869-8400, Fax: (425)869-8445 www.trend-controls.com